

EG4[®] GRIDBOSS

USER MANUAL



TABLE OF CONTENTS

1.	TECHNICAL SPECIFICATIONS.....	1
2.	ABBREVIATIONS	3
3.	SAFETY.....	4
3.1	SYMBOLS USED IN MANUAL.....	4
3.2	SYMBOLS USED ON EQUIPMENT	4
4.	SAFETY INSTRUCTIONS & NOTIFICATIONS.....	5
4.1	SAFETY INSTRUCTIONS.....	5
4.2	IMPORTANT SAFETY NOTIFICATIONS.....	5
5.	SÉCURITÉ.....	7
5.1	INSTRUCTIONS DE SÉCURITÉ	7
5.2	NOTIFICATIONS IMPORTANTES DE SÉCURITÉ.....	7
6.	PRODUCT OVERVIEW	9
6.1	DIMENSIONS	11
6.2	PACKING LIST	12
7.	INSTALLATION.....	13
7.1	MOUNTING AREA & SPACING REQUIREMENTS.....	14
7.2	RECOMMENDED TOOLS	16
7.3	MOUNT THE UNIT	16
7.4	INSTALL BREAKERS.....	19
7.5	INSTALL CABLES.....	29
7.6	CONFIGURE THE HYBRID INVERTERS.....	40
7.7	CONFIGURE GRIDBOSS.....	41
7.8	VERIFY CONFIGURATION.....	43
8.	SYSTEM OPERATION & CONFIGURATION EXAMPLES	45
8.1	HYBRID INVERTERS.....	45
8.2	GENERATOR.....	48
8.3	MANUAL BYPASS MODE.....	49
8.4	SMART LOADS.....	50
8.5	AC COUPLING.....	53
9.	REMOTE SYSTEM MANAGEMENT.....	55
9.1	CREATE NEW ACCOUNT.....	56
9.2	EXISTING ACCOUNTS.....	58
10.	EG4 MONITOR CENTER.....	60
10.1	MAINTENANCE TAB.....	61
11.	FIRMWARE UPDATES.....	66
11.1	SYSTEM - EG4 MOBILE APP.....	66
11.2	SYSTEM - EG4 MONITOR CENTER.....	67
11.3	INVERTER LCD - USB DRIVE	68
12.	TROUBLESHOOTING.....	70
12.1	FRONT PANEL LEDS	70
12.2	ERROR CODES	70
12.3	WARNING CODES	71
12.4	INTERNAL FUSE REPLACEMENT	71
13.	CHANGELOG	76

1. TECHNICAL SPECIFICATIONS

GRID	
NOMINAL AC VOLTAGE	120/240 VAC (L1/L2/N required)
FREQUENCY	60 Hz
MAXIMUM CURRENT	200A
SERVICE ENTRANCE RATED	22kAIC with 200A Eaton CSR2200N (CSR25K) breaker*
GENERATOR	
NOMINAL VOLTAGE	120/240 VAC (L1/L2/N required)
FREQUENCY	60 Hz
MAXIMUM CURRENT	125A
NON-BACKUP	
NOMINAL VOLTAGE	120/240 VAC (L1/L2/N required)
FREQUENCY	60 Hz
MAXIMUM CURRENT	200A
BACKUP	
NOMINAL VOLTAGE	120/240 VAC (L1/L2/N required)
FREQUENCY	60 Hz
MAXIMUM CURRENT	200A
HYBRID	
NUMBER OF PORTS	3
NOMINAL VOLTAGE	120/240 VAC (L1/L2/N required)
FREQUENCY	60 Hz
MAXIMUM CURRENT PER PORT	90A**
SUPPORTED INVERTERS	EG4® 12kPV, 18kPV, FlexBOSS18, FlexBOSS21***
SMART PORTS	
NUMBER OF PORTS	4
NOMINAL VOLTAGE	120/240 VAC (L1/L2/N required)
FREQUENCY	60 Hz
MAXIMUM CURRENT PER PORT	1: 125A 2: 80A 3: 60A 4: 60A
GENERAL DATA	
COMMUNICATION INTERFACE	RS485/Wi-Fi/CAN
IDLE CONSUMPTION	~55W
TRANSFER TIME	~25 ms
INTERNAL BUS RATING	350A (software limited to 200A)
INTERNAL FUSE RATING	315A
OPERATING ALTITUDE	<6561 ft (<2000 m)****
RELATIVE HUMIDITY	0 – 100%
OUTDOOR RATING	NEMA 3R
OPERATING AMBIENT TEMPERATURE RANGE	-40°F – 113°F (-40°C – 45°C)
PRODUCT DIMENSIONS (H×W×D)	31.5×19.7×7 in (800×500×178 mm)
UNIT WEIGHT	55 lbs. (25 kg)
STANDARD WARRANTY	10-year standard warranty*****

*US only.

**Install a properly sized breaker for the attached inverter: 50A - 12kPV | 70A - 18kPV, FlexBOSS18 | 90A - FlexBOSS21.

***Third-party inverters are not supported and cannot be connected to the hybrid ports.

****For installations above 2000 m, the inverter needs to be derated to specific values depending on the elevation. Refer to the "Inverter Altitude and Derating Usage Restrictions" guide by navigating to <https://eg4electronics.com/wp-content/uploads/2026/04/EG4-Inverter-Altitude-Derating-Usage-Restrictions.pdf> or by scanning the QR code below.



*****For information regarding warranty registration on EG4® Electronics products, please navigate to <https://eg4electronics.com/warranty/> and select the corresponding product to begin the registration process.

STANDARDS AND CERTIFICATIONS

UL1741, UL67, UL869A*, UL916, CSA C22.2#29:2015 ED.6+U1**, CSA C22.2#107.1:2015 ED.6+U1***

FCC PART 15, CLASS B

*When used with a 200A Eaton CSR2200N (CSR25K) main breaker, US only.

**Not service entrance rated.

***Model MI-200-2P-HYB-AW-04 not service entrance rated.

2. ABBREVIATIONS

- AWG – American Wire Gauge
- A – Amps
- Ah – Amp hour(s)
- AC – Alternating Current
- AFCI – Arc-Fault Circuit Interrupter
- AHJ – Authority Having Jurisdiction
- kAIC – kilo-Amp Interrupting Capability
- ANSI – American National Standards Institute
- BAT – Battery
- BMS – Battery Management System
- COM – Communication
- CT – Current Transformer
- DC – Direct Current
- DIP – Dual In-line Package
- DOD – Depth of Discharge
- EG – Equipment Ground
- EGS – Equipment Grounding System
- EMC – Electromagnetic Compatibility
- EPS – Emergency Power System
- ESS – Energy Storage System
- E-Stop – Emergency Stop
- FCC – Federal Communication Commission
- GE – Grounding Electrode
- GEC – Grounding Electrode Conductor
- GFCI – Ground Fault Circuit Interrupter
- GFDI – Ground Fault Detector/Interrupter
- Imp – Maximum Power Point Current
- IEEE – Institute of Electrical and Electronic Engineers
- IP – Ingress Protection
- Isc – Short-Circuit Current
- In-lbs. – Inch Pounds
- kW – Kilowatt
- kWh – Kilowatt-hour
- LCD – Liquid Crystal Display
- LFP – Lithium Iron Phosphate
- L1 – Line 1
- L2 – Line 2
- mm – Millimeters
- MPPT – Maximum Power Point Tracking
- mV – Millivolt
- N – Neutral
- NEC – National Electric Code
- NEMA – National Electrical Manufacturers Association
- NFPA – National Fire Protection Association
- Nm – Newton Meters
- NOCT – Normal Operating Cell Temperature
- PC – Personal Computer
- PCB – Printed Circuit Board
- PE – Protective Earth
- PPE – Personal Protective Equipment
- PV – Photovoltaic
- RSD – Rapid Shut Down
- SCC – Standards Council of Canada
- SOC – State of Charge
- STC – Standard Testing Conditions
- UL – Underwriters Laboratories
- UPS – Uninterrupted Power Supply
- V – Volts
- VOC – Open-Circuit Voltage
- VMP – Voltage Maximum Power

3. SAFETY

3.1 SYMBOLS USED IN MANUAL



DANGER

This type of notation indicates a severe hazard that presents an immediate risk of serious injury or death.



WARNING

This type of notation indicates that a hazard may pose a risk to human health and safety.



TEAM LIFT

Use team lift whenever load weight, size, or center of gravity exceeds safe single-person handling limits. Coordinated lifting improves stability, control, and significantly reduces injury risk.



CAUTION

This type of notation indicates that the hazard could potentially damage the equipment.



NOTICE

This type of notation indicates that the information provided is important for the installation, operation, and/or maintenance of the equipment. Failure to follow the recommendations in such a notation could result in the equipment warranty being voided.



NOTE

This type of notation indicates useful information.

3.2 SYMBOLS USED ON EQUIPMENT

	<p>WARNING: Read the instructions before installation, operation, and maintenance of the system.</p>
	<p>WARNING: Read the instructions before installation, operation, and maintenance of the system.</p>
	<p>WARNING: Hazardous Voltage Circuits!</p>

4. SAFETY INSTRUCTIONS & NOTIFICATIONS

4.1 SAFETY INSTRUCTIONS

International safety regulations have been strictly observed in the design and testing of the GridBOSS. Before beginning any work, carefully read all safety instructions and always observe them when working on or with the inverter. The installation must follow all applicable national or local standards and regulations.

Incorrect installation may cause:

- Injury or death to the installer, operator, or third party
- Damage to the inverter or other attached equipment

4.2 IMPORTANT SAFETY NOTIFICATIONS



DANGER

Various safety concerns must be carefully observed before, during, and after the installation, as well as during future operation and maintenance. The following are essential safety notifications for this product's installer and end users under normal operating conditions.

1. **Beware of high grid voltage.** Confirm that the AC switch and/or AC breaker are in the “off” or “open” position before installing or working on the inverter. Use a voltmeter to confirm that no voltage is present to avoid electric shock.
2. **Do not open the internal GridBOSS cover while it is operating to avoid electric shock and damage from live voltage and current within the system.**
3. Do not make any connections or remove any connections while GridBOSS is operating.
4. An installer should make sure to be well protected by reasonable and professional insulating equipment [e.g., personal protective equipment (PPE)].
5. Before installing, operating, or maintaining the system, it is important to inspect all existing wiring to confirm that it meets the appropriate specifications and conditions for use.
6. Verify that the grid connections to the inverter are secure and proper to prevent damage or injuries caused by improper installation.
7. Some components of the system can be very heavy. Be sure to use team-lift, among other safe lifting techniques, throughout the installation.



WARNING

TO REDUCE THE RISK OF INJURY, READ ALL INSTRUCTIONS!

All work on this product (system design, installation, operation, setting, configuration, and maintenance) must be carried out by qualified personnel. To reduce the risk of electric shock, do not perform any service other than those specified in the operating instructions unless qualified to do so.

8. Read all the instructions before installation. For electrical work, follow all local and national wiring standards, regulations, and these installation instructions.
9. Make sure all equipment is properly grounded. All wiring should comply with the National Electrical Code (NEC), ANSI/NFPA 70.
10. The system can interconnect with the utility grid only if the utility provider permits. Consult with the local AHJ (Authority Having Jurisdiction) before installing this product to determine any additional regulations or requirements for the immediate area.
11. All warning labels and nameplates on the inverter should be clearly visible and must not be removed or covered.
12. The installer should consider the safety of future users when choosing the correct position and location for the GridBOSS as specified in this manual.
13. Keep children from touching or misusing the inverter and relevant systems.
14. **Beware!** Do not connect any DC connections to the GridBOSS.



WARNING

Cancer and reproductive harm – Visit <https://www.p65warnings.ca.gov> for more information.

DISCLAIMER

EG4® reserves the right to make changes to the material herein at any time without notice. Please refer to www.eg4electronics.com for the most updated version of our manuals/spec sheets.

5. SÉCURITÉ

5.1 INSTRUCTIONS DE SÉCURITÉ

Les réglementations internationales de sécurité ont été strictement observées dans la conception et les tests du GridBOSS. Avant de commencer tout travail, lisez attentivement toutes les instructions de sécurité et respectez-les toujours lorsque vous travaillez sur ou avec l'onduleur. L'installation doit suivre toutes les normes et réglementations nationales ou locales applicables.

Une installation incorrecte peut causer :

- Des blessures ou la mort de l'installateur, de l'opérateur ou d'un tiers
- Des dommages à l'onduleur ou à d'autres équipements connectés

5.2 NOTIFICATIONS IMPORTANTES DE SÉCURITÉ



DANGER

Circuits de tension dangereuse !

Il existe divers problèmes de sécurité qui doivent être soigneusement observés avant, pendant et après l'installation, ainsi que pendant l'exploitation et la maintenance futures. Les notifications de sécurité suivantes sont essentielles pour l'installateur et les utilisateurs finaux de ce produit dans des conditions normales de fonctionnement.

1. **Méfiez-vous de la haute tension du réseau.** Assurez-vous que l'interrupteur AC et/ou le disjoncteur AC sont en position "off" ou "ouvert" avant d'installer ou de travailler sur l'onduleur. Utilisez un voltmètre pour confirmer qu'il n'y a pas de tension présente afin d'éviter les chocs électriques.
2. **Ne pas ouvrir le couvercle interne du GridBOSS pendant son fonctionnement pour éviter les chocs électriques et les dommages dus à la tension et au courant en direct dans le système.**
3. Ne pas effectuer de connexions ni retirer de connexions pendant que le GridBOSS fonctionne.
4. Un installateur doit s'assurer d'être bien protégé par un équipement isolant raisonnable et professionnel (par exemple, équipement de protection individuelle - EPI).
5. Avant d'installer, d'exploiter ou de maintenir le système, il est important d'inspecter tous les câblages existants pour s'assurer qu'ils répondent aux spécifications et conditions appropriées pour l'utilisation.
6. Assurez-vous que les connexions du réseau à l'onduleur sont sécurisées et appropriées pour éviter les dommages ou les blessures causés par une installation incorrecte.
7. Certains composants du système peuvent être très lourds. Assurez-vous d'utiliser des techniques de levage en équipe, parmi d'autres techniques de levage sûres, tout au long de l'installation.



WARNING

AVERTISSEMENT : POUR RÉDUIRE LE RISQUE DE BLESSURE, LISEZ TOUTES LES INSTRUCTIONS !

Tous les travaux sur ce produit (conception du système, installation, exploitation, réglage, configuration et maintenance) doivent être effectués par du personnel qualifié. Pour réduire le risque de choc électrique, ne réalisez aucun service autre que ceux spécifiés dans les instructions de fonctionnement, sauf si vous êtes qualifié pour le faire.

8. Lisez toutes les instructions avant l'installation. Pour les travaux électriques, suivez toutes les normes et réglementations locales et nationales de câblage, ainsi que ces instructions d'installation.
9. Assurez-vous que tout l'équipement est correctement mis à la terre. Tous les câblages doivent être conformes au Code National de l'Électricité (NEC), ANSI/NFPA 70.
10. Le système peut se connecter au réseau public uniquement si le fournisseur de services publics le permet. Consultez l'autorité locale compétente (AHJ) avant d'installer ce produit pour toute réglementation et exigence supplémentaire pour la zone immédiate.
11. Toutes les étiquettes d'avertissement et les plaques signalétiques sur l'onduleur doivent être clairement visibles et ne doivent pas être retirées ou couvertes.
12. L'installateur doit prendre en compte la sécurité des futurs utilisateurs lors du choix de la position et de l'emplacement corrects pour le GridBOSS, comme spécifié dans ce manuel.
13. Empêchez les enfants de toucher ou de mal utiliser l'onduleur et les systèmes pertinents.
14. **Attention !** Ne connectez aucune connexion DC au GridBOSS.



WARNING

AVERTISSEMENT !

Cancer et dommages reproductifs – voir www.p65warnings.ca.gov pour plus de détails.

DISCLAIMER

EG4® se réserve le droit de modifier le contenu de ce document à tout moment sans préavis. Veuillez consulter www.eg4electronics.com pour la version la plus récente de nos manuels/fiches techniques.

6. PRODUCT OVERVIEW

The EG4® GridBOSS is a service entrance–rated intelligent power distribution device that uses software, relays, and programmable smart ports to direct power where and when it is needed. The system supports four possible AC input sources to meet different system design requirements: the grid, up to three hybrid inverters, a generator, and AC coupling ports. The system distributes power to the backup loads port, the smart ports, and the non-backup loads port. Smart ports commonly support power shedding for loads such as electric vehicles, water heaters, and HVAC units. These ports also support the connection of AC-coupled photovoltaic (PV) systems, providing an additional power source. The unit supports AC pass-through current up to 200 amps, enabling intelligent power distribution for end users. Typical application scenarios appear in the image below, along with configuration examples described in Section 8.

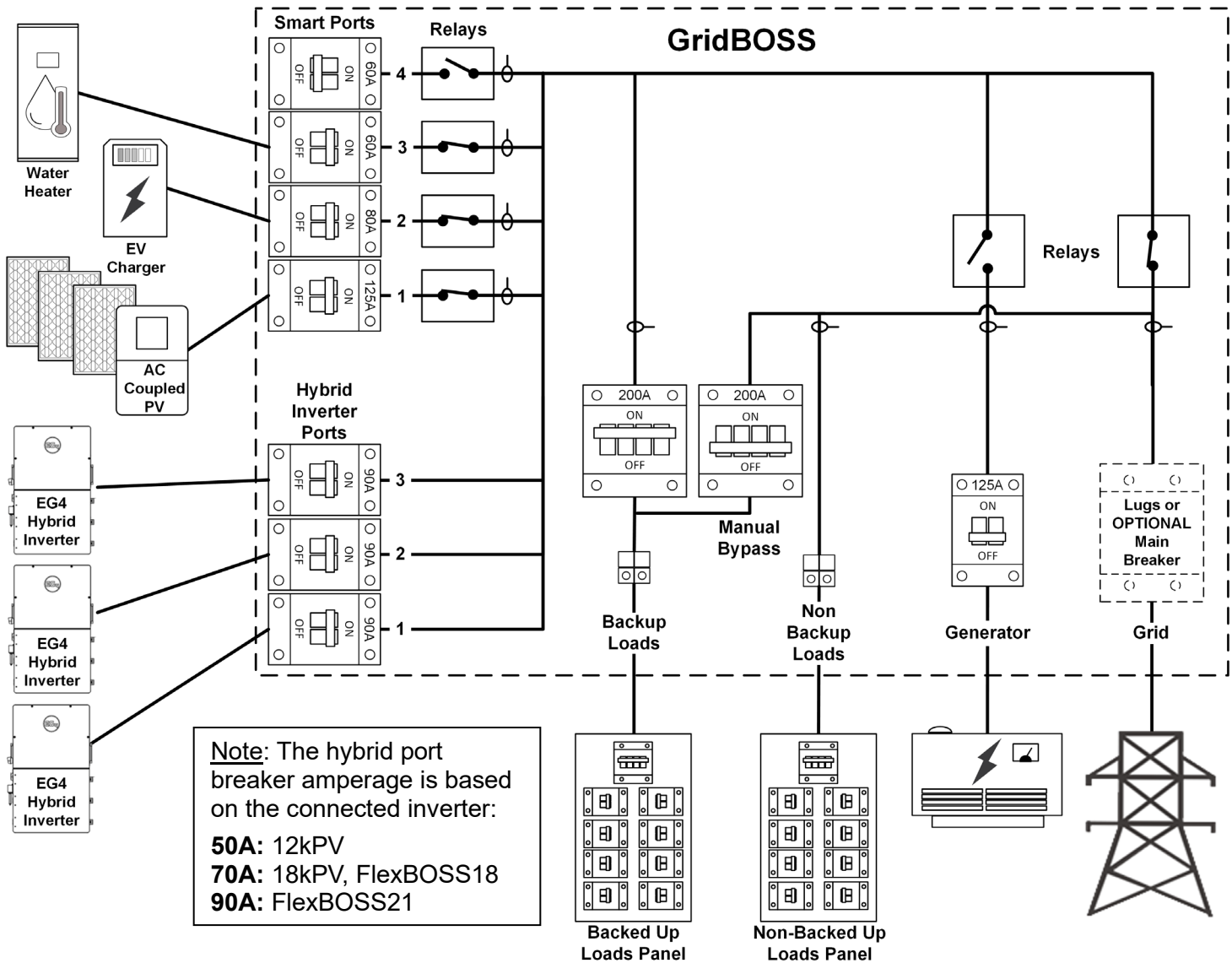

NOTICE

The breakers shown in the image above represent the maximum supported sizes for each port. The system sets the maximum total output amperage at 200 amps. If the current draw exceeds 200A, the GridBOSS begins limiting load output.

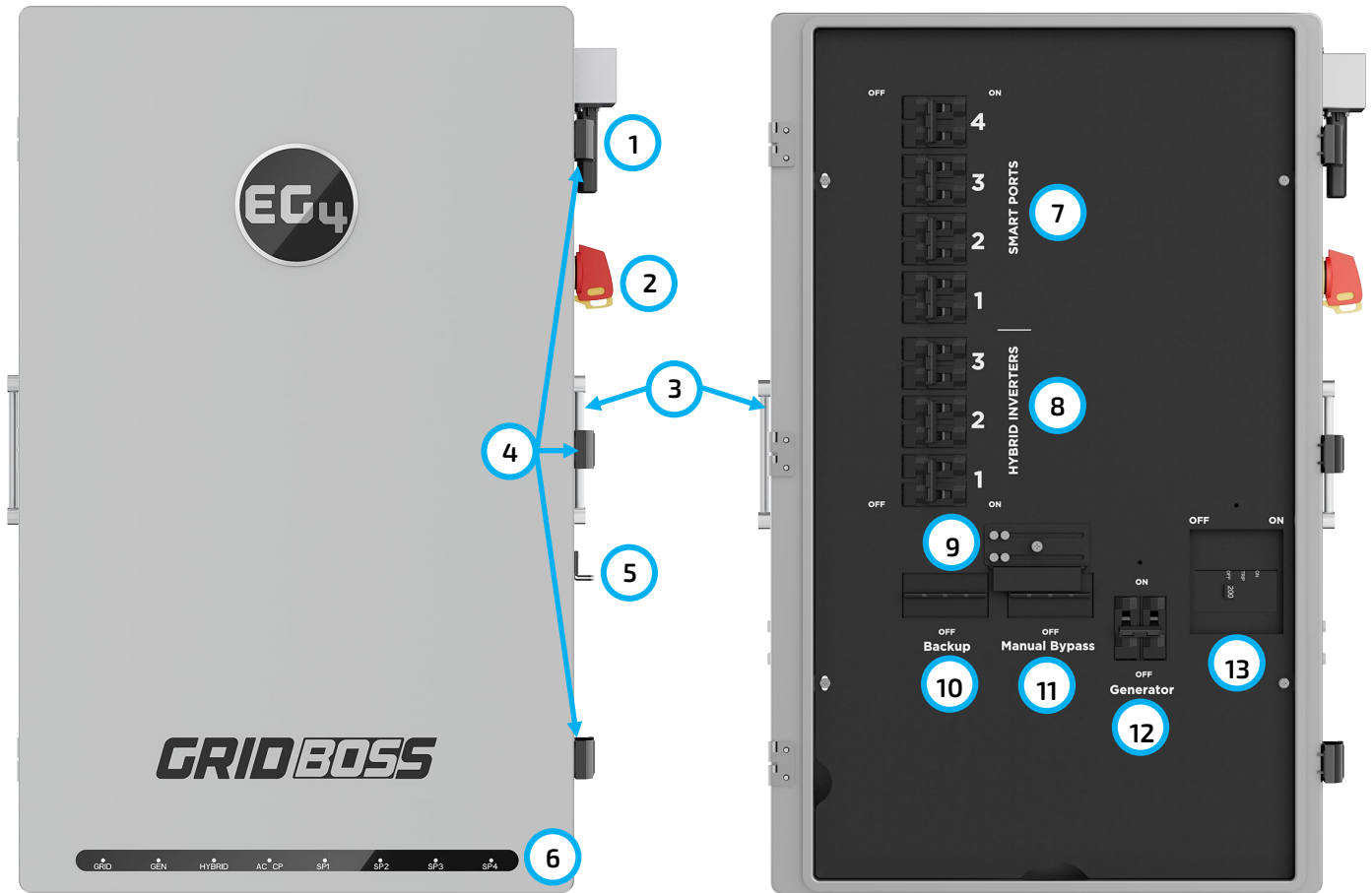

ITEM	DESCRIPTION
1	Wi-Fi dongle
2	RSD/ESS switch
3	Chassis handles
4	Door latches
5	Door lock mechanism for padlock
6	Port LEDs
7	Smart port breakers
8	Hybrid port breakers
9	Manual bypass interlock
10	Backup port breaker
11	Manual bypass breaker
12	Generator breaker
13	Grid breaker (optional)

6.1 DIMENSIONS

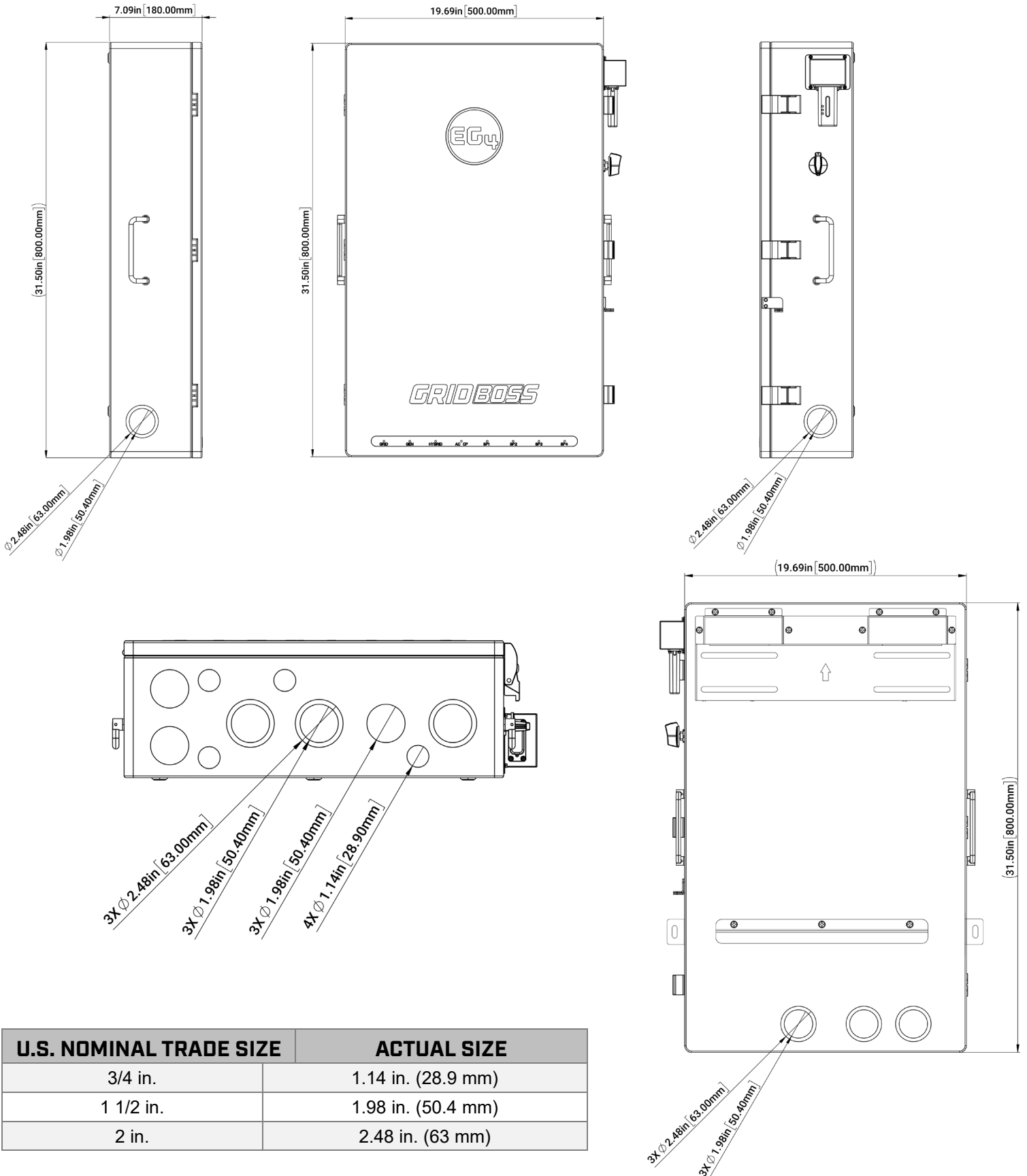

U.S. NOMINAL TRADE SIZE	ACTUAL SIZE
3/4 in.	1.14 in. (28.9 mm)
1 1/2 in.	1.98 in. (50.4 mm)
2 in.	2.48 in. (63 mm)

6.2 PACKING LIST

Each product shipment includes the items listed below:

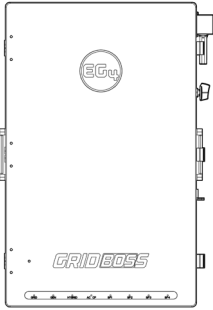

GridBOSS (x1)

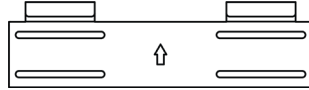

Mounting Bracket (x1)

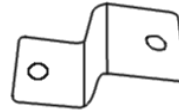

Neutral-Ground Bonding Jumper (x1)

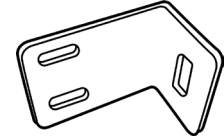

L-Bracket (x2)

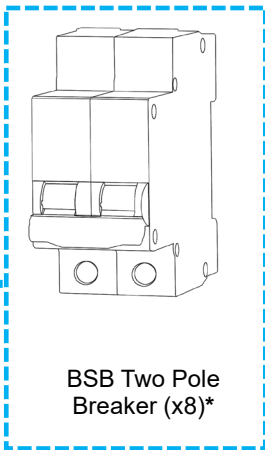

BSB Two Pole Breaker (x8)*



Breaker Cover (x1)

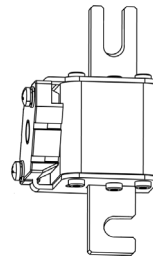

Extra Fuse (x2)

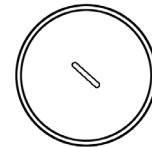

Waterproof Cover

- M63 (x8)
- G-M50 (x3)
- G-P21 (x4)

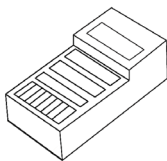

RJ45 Connector (x3)

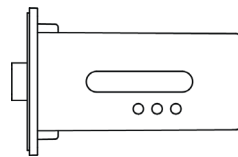

Wi-Fi Dongle (x1)



Expansion Screws & Tubes (x6)

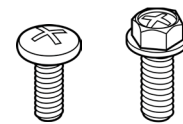

Cross Head Screws:

- M3-0.5*12 mm (x4)
- M4-0.7x12 mm (x2)
- M4-0.7x12 mm (Green) (x1)
- M5-0.8x10 mm (x4)
- M5-0.8x16 mm (x4)
- M6-1x38 mm (x1)
- M6-1x16 mm (x2)

* Model 3 hardware SKU EG4MID2P200AV3 includes BSB breakers: 30A (x1), 40A (x1), 60A (x2), 80A (x1), 90A (x3). SKU EG4MID2P200AV3.1 does not include breakers. Model 4 hardware does not include breakers. See section 6.4 for more information on supported breakers.

7. INSTALLATION

This section outlines the steps for installing and configuring the GridBOSS. Complete each section in the order listed below.

Installation Steps:

- 7.1 Mounting area and spacing requirements
- 7.2 Recommended tools
- 7.3 Mount the unit
- 7.4 Install breakers
- 7.5 Install cables
- 7.6 Configure hybrid inverters
- 7.7 Configure GridBOSS
- 7.8 Verify Configuration

WARNING

The GridBOSS is available in multiple models associated with specific hardware variations. During installation, the user manual must correspond to the exact model number of the unit. Using an incorrect manual version may lead to compliance or certification issues, installation errors, potential harm to the installer, or damage to the GridBOSS and connected components.

For additional information, scan the QR code to access the “GridBOSS Model Versioning Whitepaper.”



The model number appears on the informational label located on the lower left side of the GridBOSS chassis. The example below shows Model 3.

EG4 ELECTRONICS		Grid BOSS
Model	MI-200-2P-HYB-AW-03	
Grid		
Nominal Voltage	120/240VAC	
Frequency	60Hz	
Maximum Current	200A	
Adjustable Displacement Factor Range	+/-0.8	
Generator		
Nominal Voltage	120/240VAC	
Frequency	60Hz	
Maximum Current	125A	
Non Backup		
Nominal Voltage	120/240VAC	
Frequency	60Hz	
Maximum Current	200A	



The model number in the User Manual appears on the cover page in the lower left corner. The example below illustrates Model 3.



©2025 EG4® ELECTRONICS, LLC. ALL RIGHTS RESERVED.
 VERSION 2.0.0 | INFORMATION SUBJECT TO CHANGE WITHOUT NOTICE.
MODEL #: MI-200-2P-HYB-AW-03

7.1 MOUNTING AREA & SPACING REQUIREMENTS

Follow the requirements below for system installation:

1. The mounting wall must be strong enough to support the total weight of all equipment, including the GridBOSS, inverters, and wall-mounted batteries.
2. Maintain the minimum clearances on all sides (refer to the next page).
3. The mounting surface must consist of non-combustible material.
4. The installation location must provide adequate space for electrical connections and servicing the unit.
5. Avoid installing the GridBOSS in direct sunlight.
6. The installation location must allow a maximum relative humidity of 100%.
7. The location must maintain an ambient temperature range from -40°F (-40°C) to 113°F (45°C).
8. Do not install the equipment near combustible materials.
9. The maximum supported distance between the GridBOSS and connected hybrid inverters is 260 feet (80 meters). This distance supports proper communication using a CAT5 or higher straight-through network cable configured in the 568B format.
10. The installation location must comply with local codes and the requirements of UL 514B.
11. Mount the unit on a vertical surface. Do not install the unit upside down!

Must be installed vertically between a 75° – 90° angle.

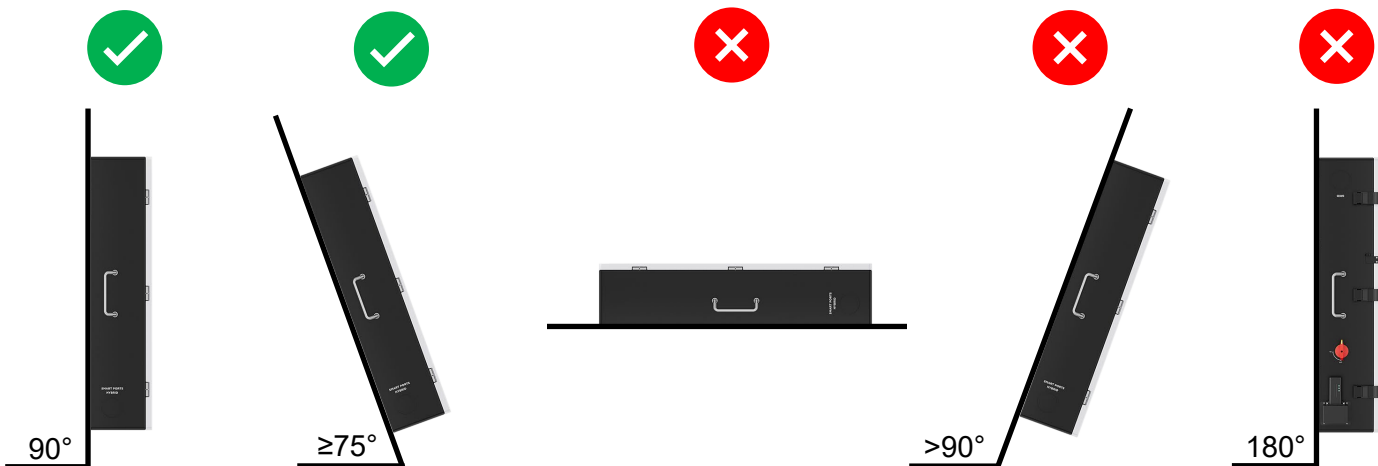

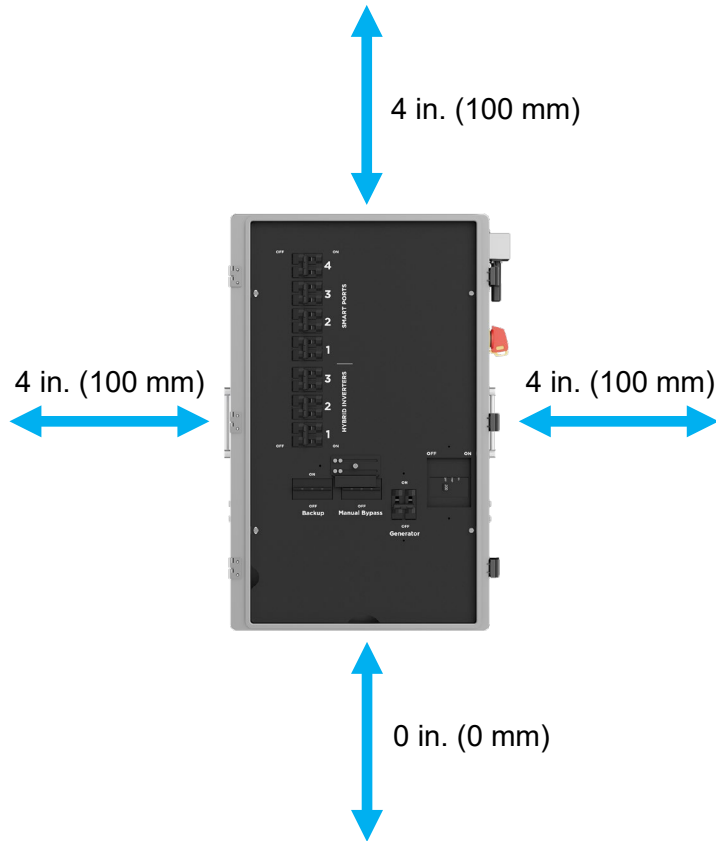

Maintain the spacing requirements shown in the image to allow full door opening and clear visibility of the dongle LEDs.

Provide adequate space in front of the unit to allow sufficient working clearance and unobstructed movement of the front cover when it swings open.

The GridBOSS mounts to a wall using the included wall-mount bracket.

Install the unit vertically on a solid, non-combustible surface such as brick or concrete.

The mounting bracket's slots can accommodate stud spacings from 12 in. (305 mm) to 16 in. (406 mm).

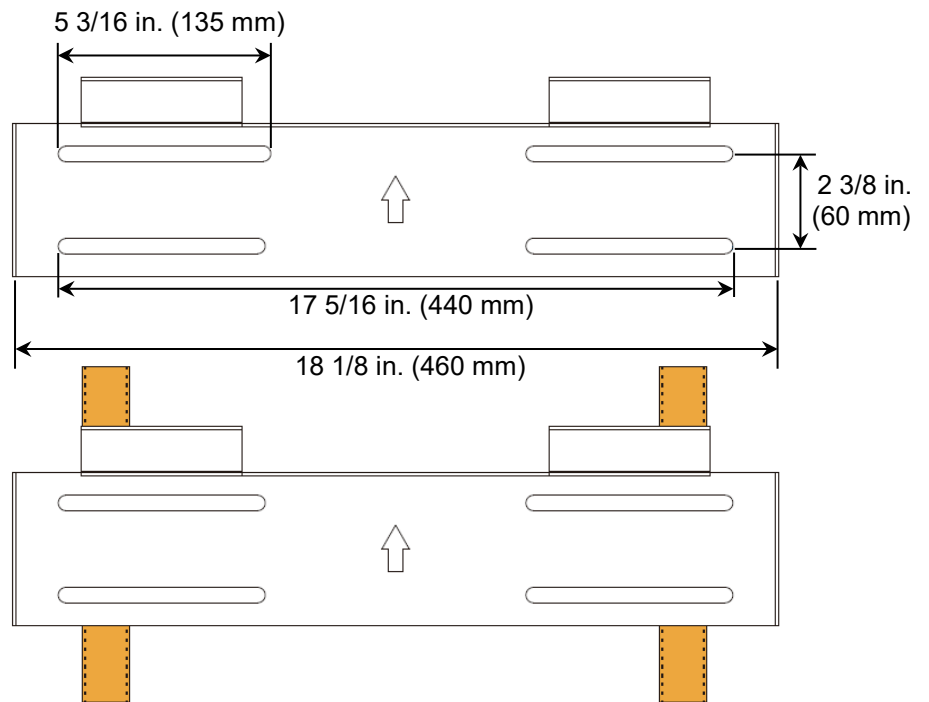

7.2 RECOMMENDED TOOLS



7.3 MOUNT THE UNIT

1. Select a suitable location for installing the GridBOSS, as described in Section 7.1.
2. Use the wall-mounting bracket as a template to mark the screw locations. When mounting the bracket to studs, verify that the screw marks align with the center of each stud.

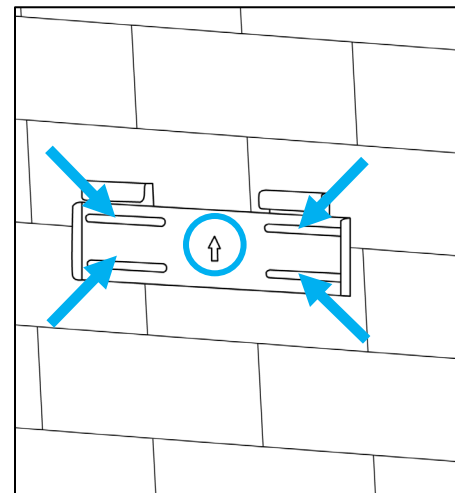

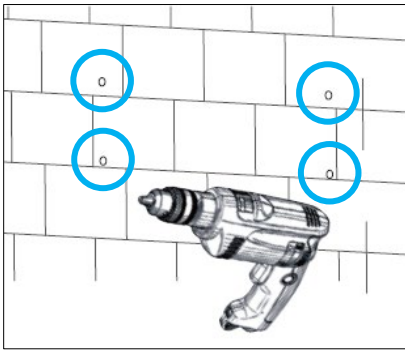

3. When installing the bracket to concrete or brick, drill 25/64-inch (10 mm) diameter holes at the marked locations. The holes must extend deeper than 3-3/16 in. (80 mm) when using the included expansion bolts.

When installing the bracket to a stud, drill pilot holes appropriate for the diameter of the screws used (screws not included).

4. For concrete or brick wall installation, insert the expansion bolts into the drilled holes. Position the bracket on the wall with the arrow pointing upward, then secure it using the corresponding nuts and washers packaged with the expansion bolts.

For stud wall installation, attach the bracket to the wall using appropriately sized screws.

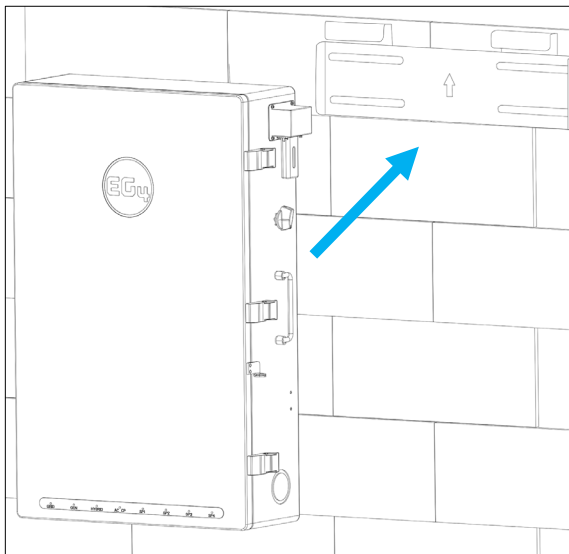
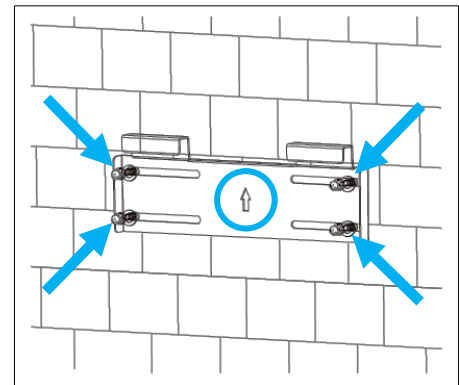

5. Use a team-lift technique to place the GridBOSS onto the wall bracket, then secure the unit to the wall.

6. Temporarily mount the L-brackets to the sides of the GridBOSS at the bottom (one on each side). Mark the wall through the hole in each L-bracket to indicate the mounting locations. Repeat this step for both sides.

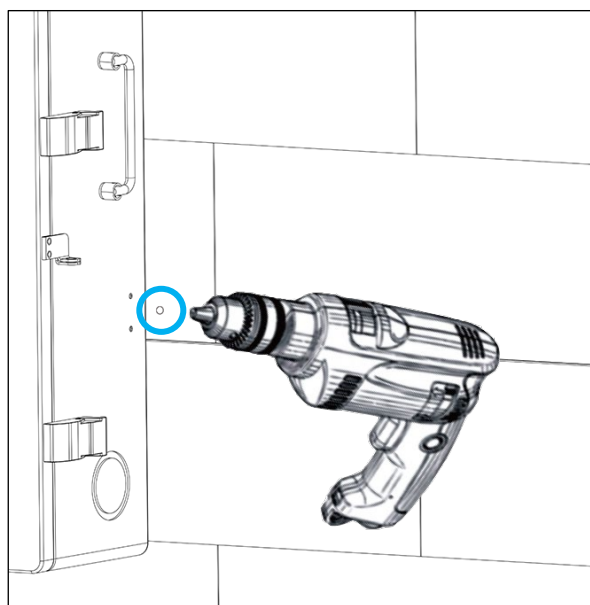
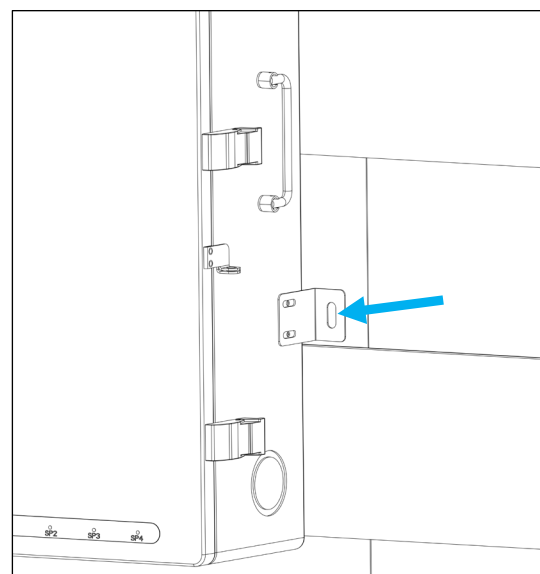

7. Remove the L-brackets and drill holes at the marked locations. Select the drill bit size based on the anchor type or screw size specified in Step 3. Repeat this step for both sides.

8. Attach the L-brackets (one on each side) to the GridBOSS and the wall using the appropriate hardware. Once the brackets are secured, the wall installation is complete.

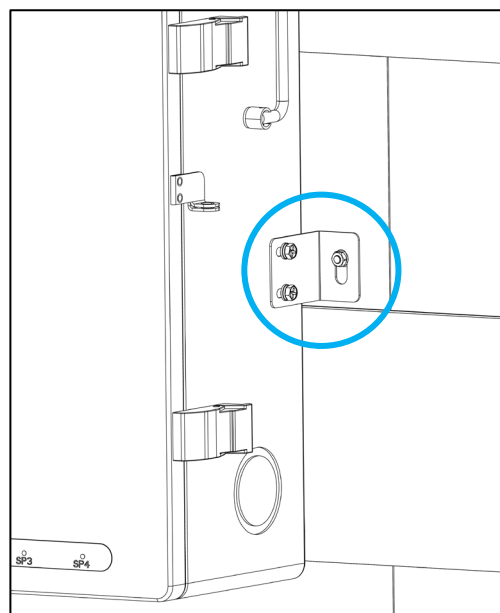

7.4 INSTALL BREAKERS

This section outlines the steps for installing the hybrid, generator, and smart port breakers, as well as the optional main breaker.

Begin the installation by opening the front door and releasing the clasps located on the right side of the unit. Remove the four screws shown in the image below, then carefully lift the inner black cover from the chassis. After removing the cover, refer to the guidance in this section to install each breaker.

DANGER

If a breaker is installed after the system enters operation, verify that all breakers remain in the OFF position and confirm that there is no voltage at each breaker and lug connection point.



BREAKER PLACEMENT AND INSTALLATION:

Refer to the chart below to identify the supported breaker brands and sizes for each port location.

PORT	SUPPORTED BREAKER SIZES	BREAKER BRAND & MODEL*	SOURCE
Grid	200A	Eaton CSR2200N (CSR25K)	Anywhere
Non-Backup	No breaker, lug only	-	-
Backup	200A (pre-installed, non-changeable)	B3T1-200	EG4 Distributor
Manual Bypass	200A (pre-installed, non-changeable)	B3T1-200	EG4 Distributor
Generator	30A, 40A, 60A, 80A, 100A, 125A	<u>BSB:</u> B3S130, B3S140, B3S160, B3S180, B3S1100, B3S1125	EG4 Distributor
		<u>Eaton:</u> BR230, BR240, BR260, BR280, BR2100, BR2125	Anywhere
Hybrid 1 – 3	12kPV: 50A 18kPV, FlexBOSS18: 70A FlexBOSS21: 90A	<u>BSB:</u> B3S150, B3S170, B3S190	EG4 Distributor
		<u>Eaton:</u> BR250, BR270, BR290	Anywhere
Smart Port 1	90A, 100A, 125A	<u>BSB:</u> B3S190, B3S1100, B3S1125	EG4 Distributor
		<u>Eaton:</u> BR290, BR2100, BR2125	Anywhere
Smart Port 1 & 2	70A, 80A	<u>BSB:</u> B3S170, B3S180	EG4 Distributor
		<u>Eaton:</u> BR270, BR280	Anywhere
Smart Port 1 – 4	30A, 40A, 50A, 60A	<u>BSB:</u> B3S130, B3S140, B3S150, B3S160	EG4 Distributor
		<u>Eaton:</u> BR230, BR240, BR250, BR260	Anywhere

* Model 3 hardware SKU EG4MID2P200AV3 includes BSB breakers: 30A (x1), 40A (x1), 60A (x2), 80A (x1), 90A (x3). SKU EG4MID2P200AV3.1 does not include breakers. Model 4 hardware does not include breakers. Refer to the table above for more information on supported breakers.

WARNING

Use COPPER WIRE only when making electrical connections to BSB breakers. The unit is not approved for other wiring types. Using non-copper wire may result in equipment damage.

NOTICE

Aluminum wire is compatible with all lug connections and Eaton breakers.

BREAKER INSTALLATION

When installing a 2-pole breaker, hold the breaker at an angle and position the bottom slot onto the metal bracket inside the GridBOSS chassis. Then pivot the breaker toward the chassis until the top snaps onto the busbar blade.

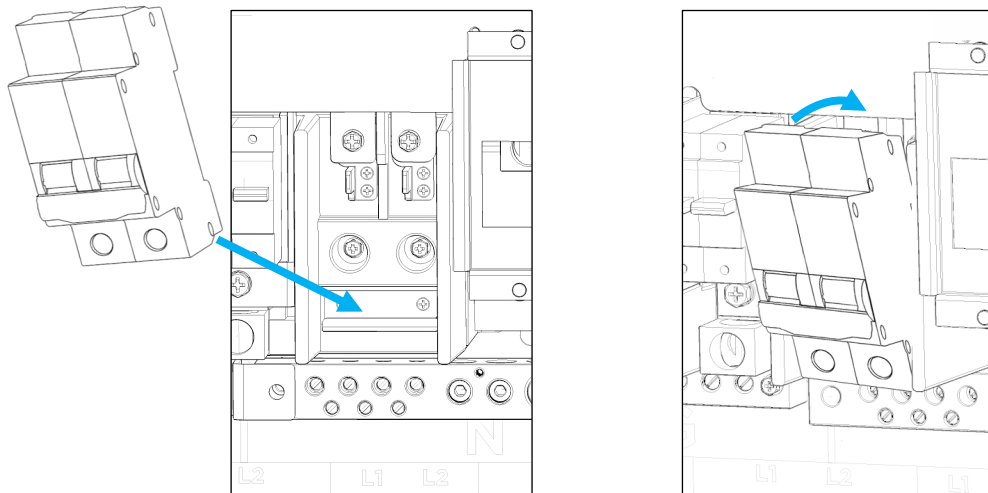

Before installing the hybrid or smart port breakers, unscrew the two M4x10 screws to detach the breaker bracket, then pull the bracket away from the chassis.

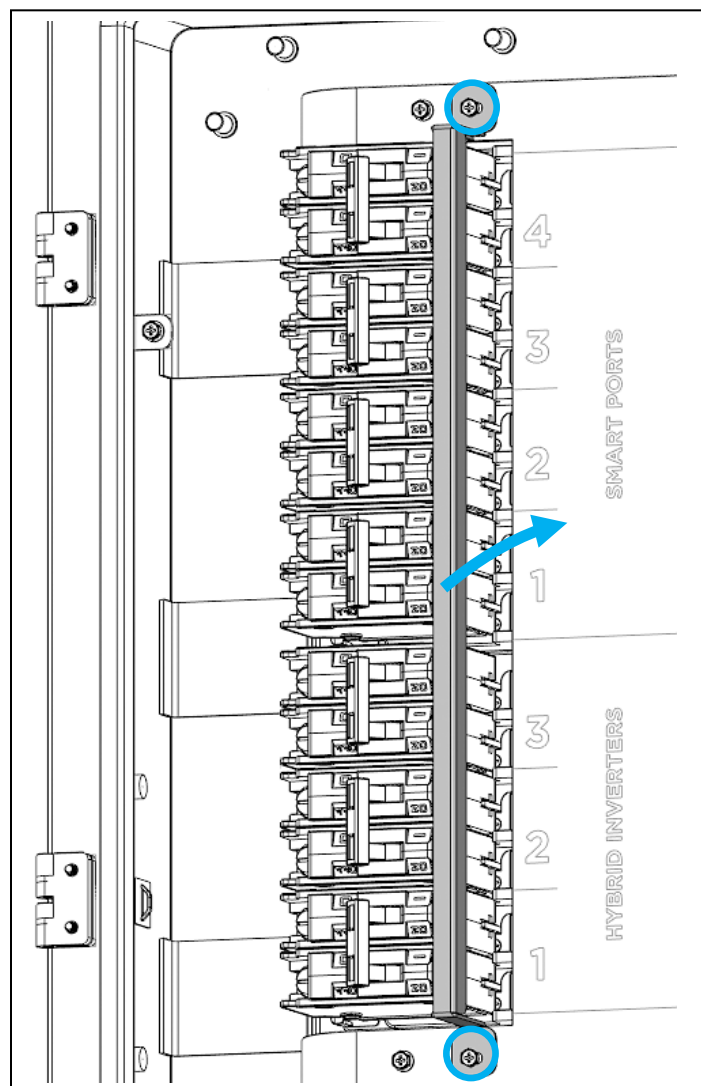

OPTIONAL MAIN BREAKER INSTALLATION



NOTE

Some main breaker installation steps and images differ between Model 3 and Model 4 hardware. Follow the steps that correspond to the model version in which the breaker is installed.

MODEL 3 HARDWARE

1. Remove the breaker bracket as illustrated on the previous page.
2. Remove the internal orange cover by first removing the two nuts using a 7mm socket and the four screws using a Phillips screwdriver. Then, lift the cover from the unit.



3. With the inside cover removed, locate the lugs for both Line 1 and Line 2, which are outlined with a dashed line. Unscrew the fastener holding each lug in place, then remove each lug.

Remove the small Phillips head screw (circled) and set it aside. This screw is reinstalled later with the main breaker.

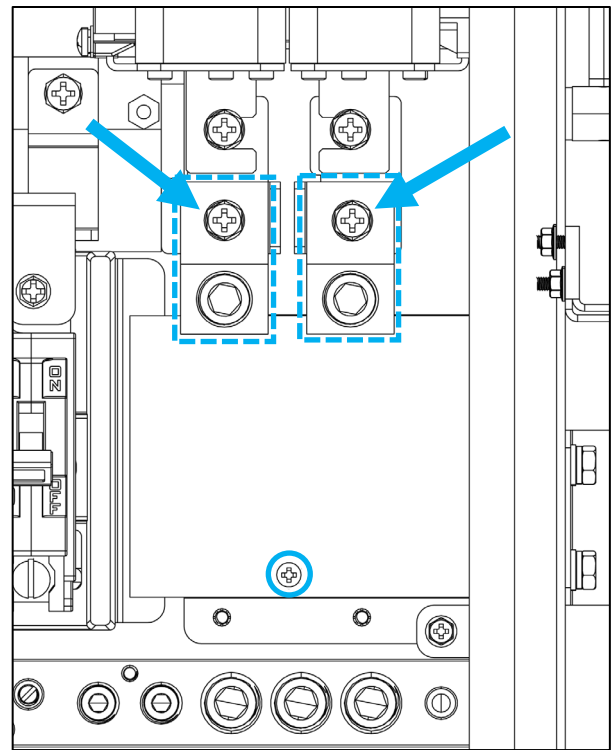

4. Position the anti-twist plates correctly to support installation of the Eaton main breaker. Remove the two screws that secure the fuses and anti-twist plates. Reinstall the anti-twist plates with the raised edges facing the fuses, as shown in the image. Finally, re-torque the screws to 80 in-lbs (9 Nm).

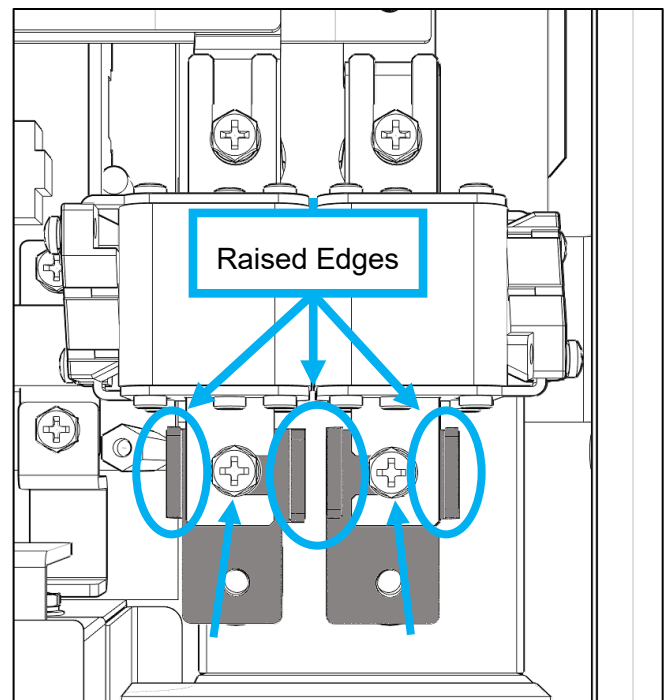

5. Before installing the breaker, adjust the position of the insulation sheet by moving the end to the right side.

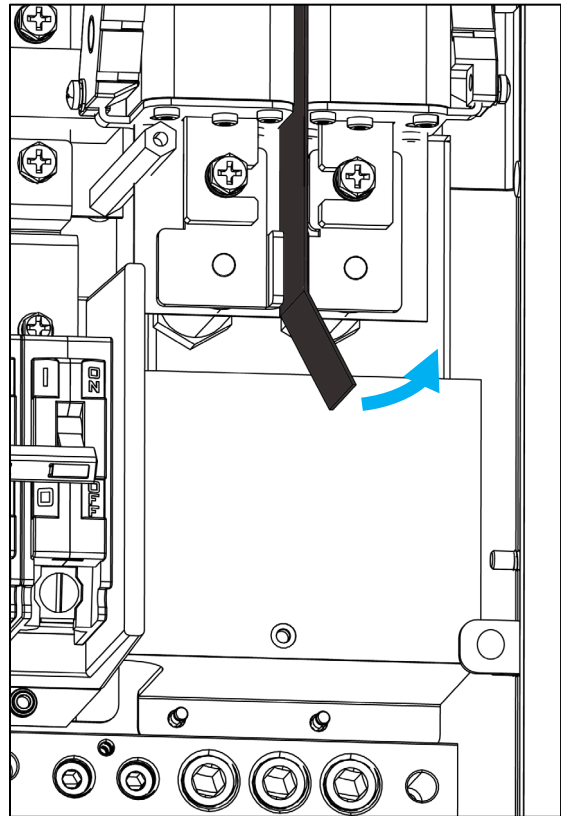

6. Install the 200A Eaton CSR2200N (CSR25K) breaker by sliding it into position and aligning the bolt holes in the breaker lugs with the holes on the busbar.

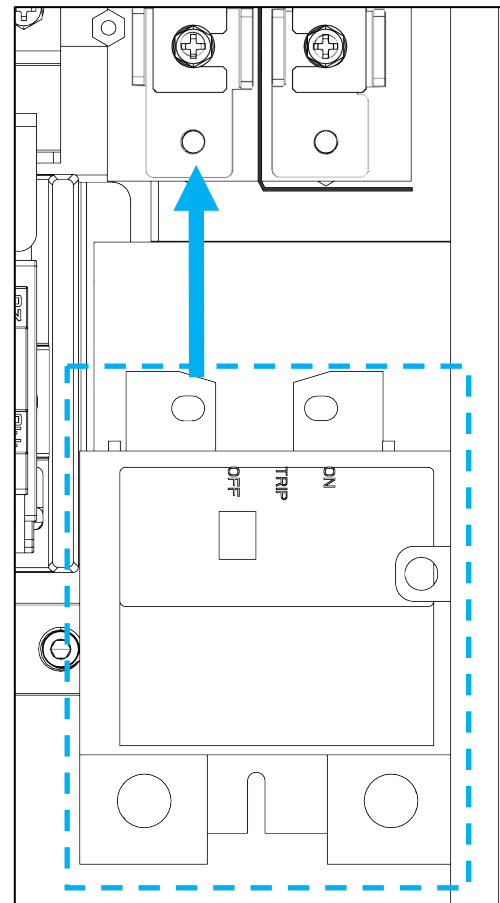

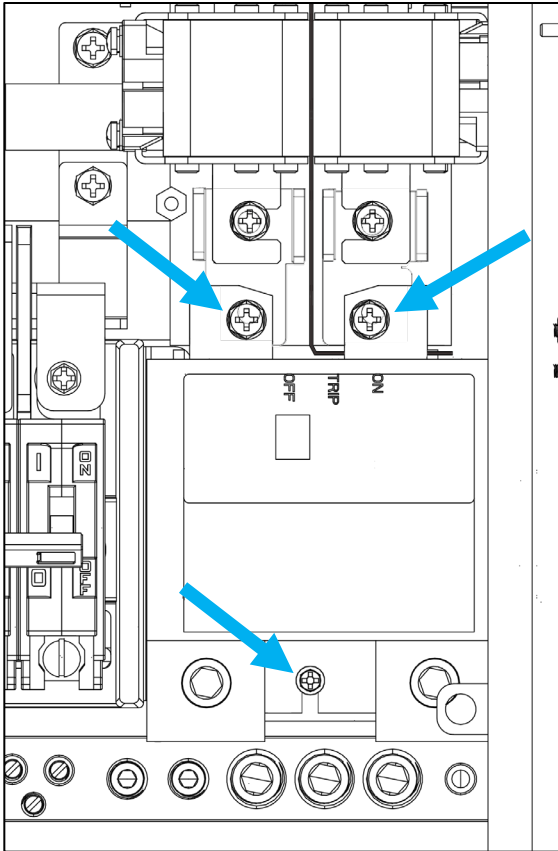

7. Using a 10 mm socket, install the two M6 screws in the busbar, then install the M4 screw that holds the opposite end of the breaker in place.

Tighten the M6 screws to 80 in-lbs. (9Nm) and the M4 screw to 10 in-lbs. (1.2Nm).

When installing the conductors to the main breaker terminals, use a 1/4-inch hex wrench and torque to 250 in-lbs. (28Nm).

8. Reinstall the orange inner cover plate removed in step 2.

9. Reinstall the breaker bracket removed in step 1.

MODEL 4 HARDWARE

1. Remove the breaker bracket as illustrated on the previous page.
2. Remove the internal orange cover by first removing the two nuts using a 7mm socket and the four screws using a Phillips screwdriver. Then, lift the cover out of the unit.



3. With the inside cover removed, locate the lugs for both Line 1 and Line 2, which are outlined with a dashed line. Unscrew the fastener holding each lug in place, then remove each lug.

Remove the small Phillips head screw (circled) and set it aside. This screw is reinstalled in a later step with the main breaker.

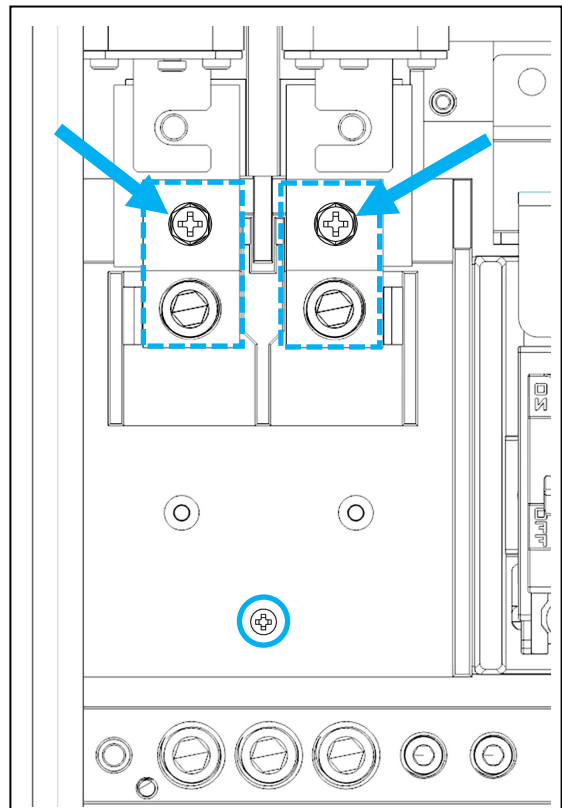

4. Remove the plastic insulation assembly by pulling it out of the chassis.

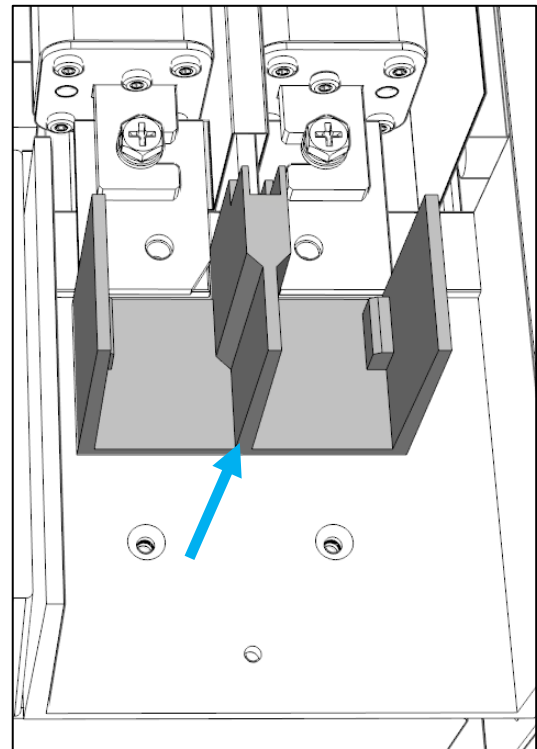

5. Install the 200A Eaton CSR2200N (CSR25K) breaker by sliding it into place, aligning the bolt holes in the breaker lugs to the holes on the busbar.

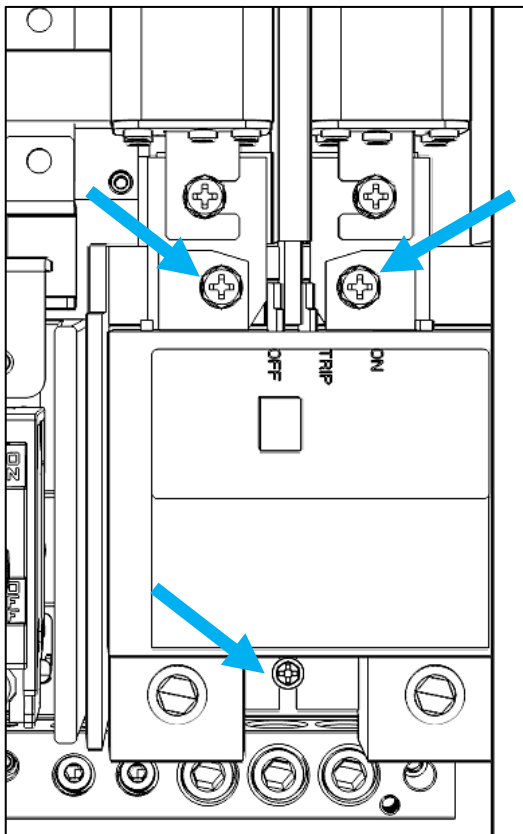
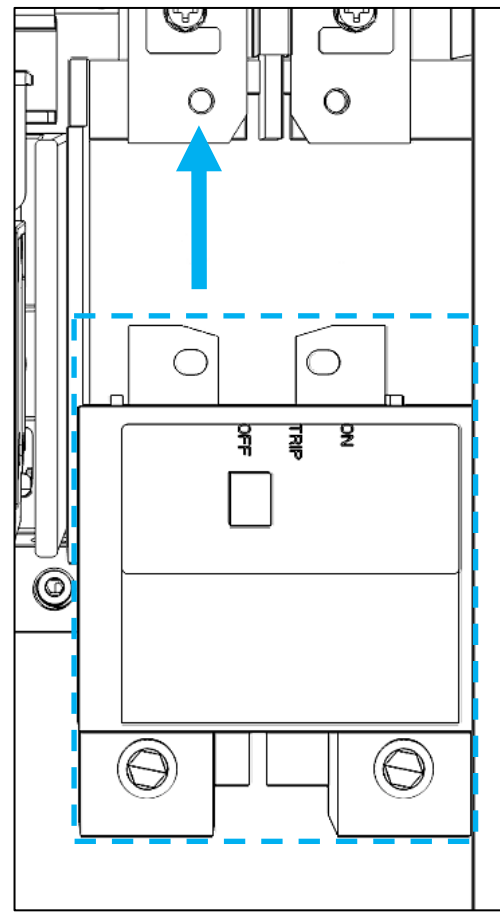

6. Using a 10 mm socket, install the two M6 screws in the busbar, then install the M4 screw that holds the opposite end of the breaker in place.

Tighten the M6 screws to 80 in-lbs. (9Nm) and the M4 screw to 10 in-lbs. (1.2Nm).

When installing the conductors to the main breaker terminals, use a 1/4-inch hex wrench and torque to 250 in-lbs. (28Nm).

7. Reinstall the orange inner cover plate removed in step 2.
8. Reinstall the breaker bracket removed in step 1.

7.5 INSTALL CABLES

Use the information in this section as guidance for connecting the AC wiring. Verify with a multimeter that each wire carries no voltage or current before making any connections to the GridBOSS.

NOTICE

The GridBOSS is Service Entrance Rated and certified under UL 869A in the United States only when installed with a 200A Eaton CSR2200N (CSR25K) breaker.

SYSTEM GROUND

The ground busbar supports connection of the GridBOSS to the building's equipment grounding system and to the grounding electrode system when used as service entrance equipment. Install the ground cable first to establish a solid ground during the wiring installation process.

LUG COUNT	SUPPORTED WIRE SIZE	MAX. TORQUE VALUE	HEX TOOL SIZE
8	14 – 4 AWG	35 in-lbs. (4.5Nm)	1/8 inch
6	4 – 2 AWG	50 in-lbs. (5.6Nm)	5/32 inch

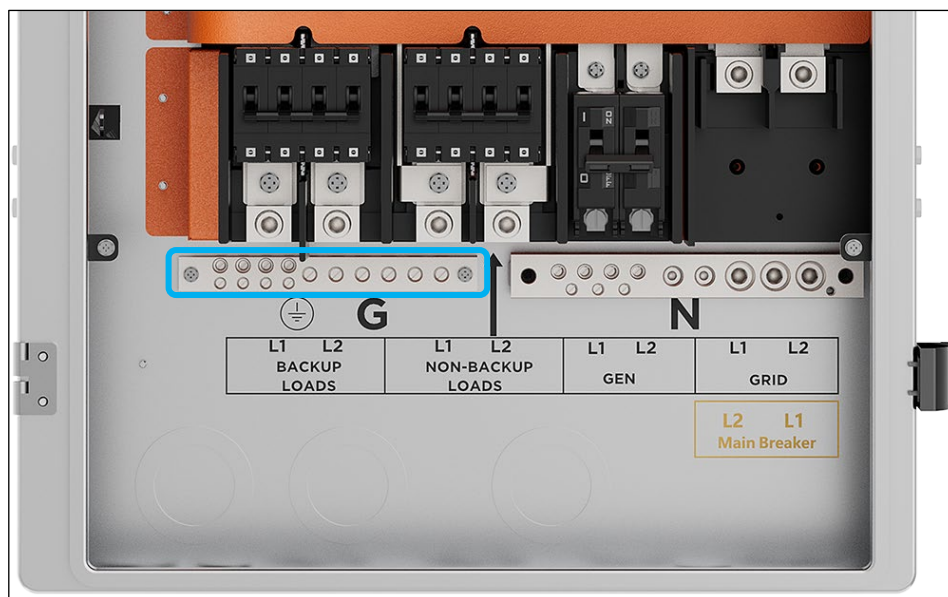

NEUTRAL WIRING AND BONDING

The neutral busbar supports the interconnection of the neutral wires within the electrical system.

LUG COUNT	SUPPORTED WIRE SIZE	MAX. TORQUE VALUE	HEX TOOL SIZE
7	14 – 4 AWG	35 in-lbs. (4Nm)	1/8 inch
2	3 – 2/0 AWG	94 in-lbs. (10Nm)	3/16 inch
3	2/0 AWG – 250 kcmil	275 in-lbs. (31Nm)	5/16 inch (8 mm)

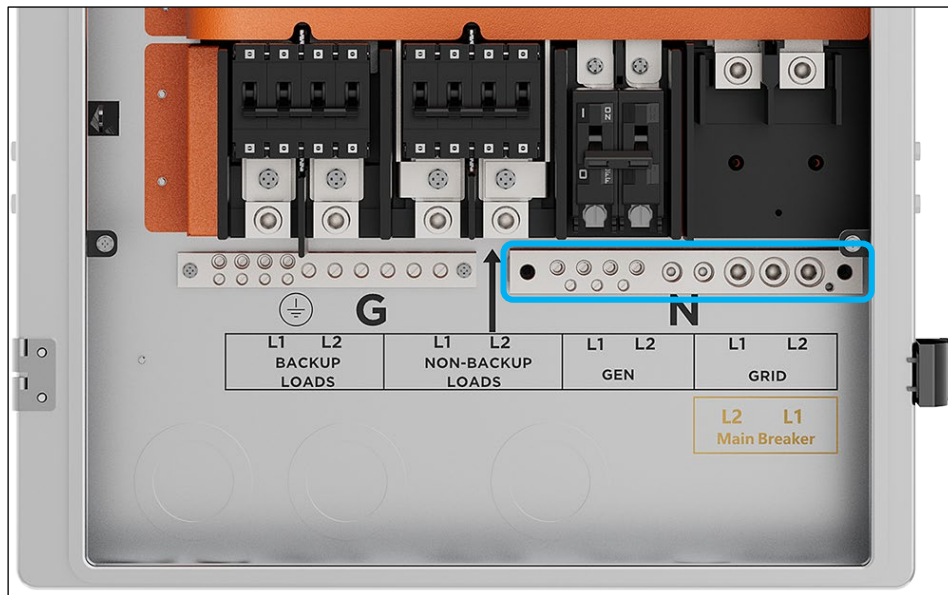

NEUTRAL GROUND BOND

The unit includes a neutral-ground bonding jumper (bracket) that connects the ground bar to the neutral bar. Install this jumper only when the GridBOSS functions as the first service disconnect, since an electrical system allows only one neutral bonding point. Attach the jumper to the neutral bar side using the M6-1×38 mm screw included in the unit packaging.

A typical use case occurs when the GridBOSS is installed directly after the power meter and configured as the first service disconnect. In this configuration, installation of the 200A Eaton CSR2200N (CSR25K) breaker in the GridBOSS is required.

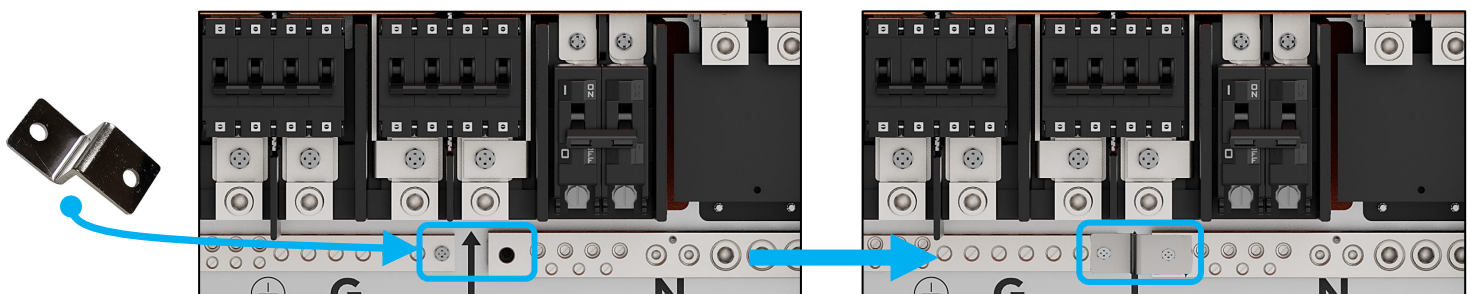

If a first service disconnect is already installed after the power meter, connect the GridBOSS in series with the existing service disconnect. In this configuration, do not install the bonding jumper. For questions regarding the neutral-ground bond, consult a licensed electrician for assistance.

NOTICE

The system must have one and only one neutral-ground bond, typically provided by the main bonding jumper at the first service entrance disconnect.

GRID PORT

The grid input supplies power to the GridBOSS in a grid-assisted configuration. Two configuration options are available when connecting to the grid. The first option uses lugs, which are factory installed. The second option uses the optional 200A Eaton CSR2200N (CSR25K) breaker, which must be purchased separately. For installation of the 200A Eaton breaker, follow the steps in Section 7.4.

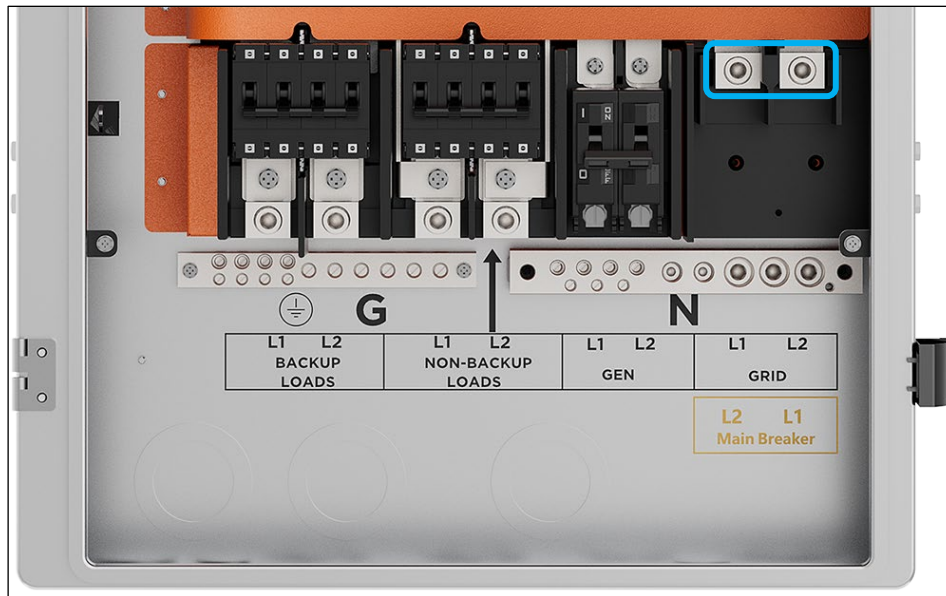

Refer to the the table below for wire size and torque recommendations when connecting the grid port wiring.

BREAKER SIZE	MAX. SUPPORTED BREAKER SIZE	SUPPORTED WIRE SIZE	MAX. TORQUE VALUE	TOOL SIZE
Lugs	-	4 – 2/0 AWG	110 in-lbs. (12Nm)	5/16 in. (8 mm)
		3/0 AWG – 250 kcmil	275 in-lbs. (31Nm)	5/16 in. (8 mm)
200A (optional)	200A	4/0 AWG – 300 kcmil	250 in-lbs. (28Nm)	1/4-inch hex

GENERATOR PORT

The GridBOSS supports supplemental 240 VAC generator power for backup operation and battery charging during a grid failure. When grid power is unavailable, the generator port can supply power to the backup port, hybrid ports, and configured smart ports. To support automatic generator startup, the GridBOSS includes a 2-wire start/stop terminal for controlling generators with 2-wire start capability.

For optimal performance, a generator with Total Harmonic Distortion (THD) below 12% is recommended. Achieve lower THD by sizing the generator to at least 1.5× the total output of all inverters, which supports both load operation and battery charging.

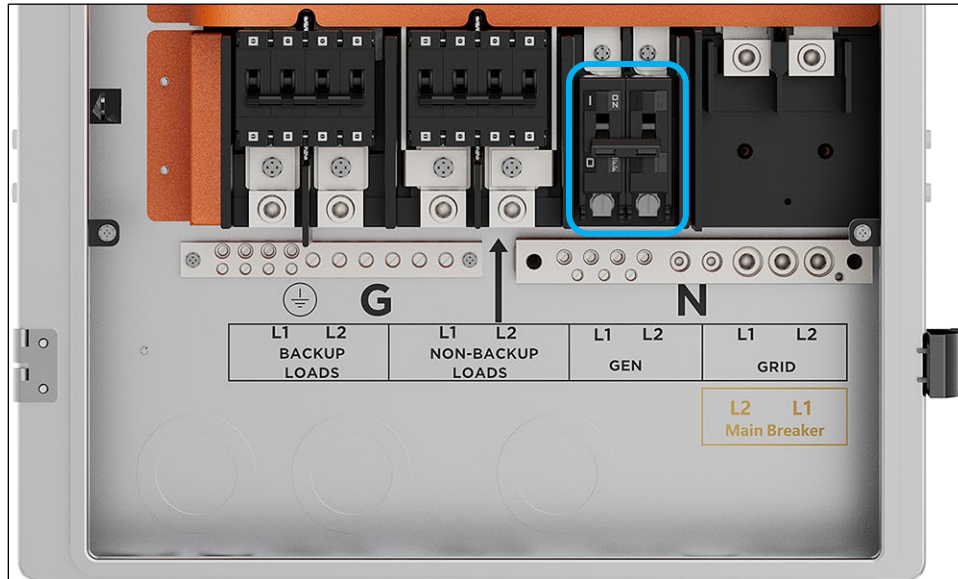

NOTE

When operating a hybrid inverter with the GridBOSS, generator support is provided exclusively through the GridBOSS generator port. Do not use the generator port on the hybrid inverter.

Refer to the table below for wire size and torque recommendations when connecting the generator port wiring.

SUPPORTED BREAKER SIZE	SUPPORTED WIRE SIZE*	MAX. TORQUE VALUE
80A, 100A, 125A	4 – 2/0 AWG	use torque value printed on breaker
30A, 40A, 60A	10 – 4 AWG	

*Size wire according to breaker amperage/system needs

GENERATOR OPERATION

The attached generator starts only when grid power is lost, and the generator is configured for 2-wire start/stop using the “Dry 1” contacts on the communications board. The internal grid relay and generator relay cannot close simultaneously, which prevents the generator output from feeding power back to the grid.

The GridBOSS uses Start/Stop Relay 1 in the normally open configuration. Control of Start/Stop Relay 1 can occur manually or through battery SOC or voltage logic within the EG4® Monitor Center. The generator also supports configuration of warm-up, cool-down, and exercise time.

The GridBOSS generator relay closes only after Start/Stop Relay 1 closes. Once Start/Stop Relay 1 closes, the GridBOSS waits until the generator provides stable output power. This delay is defined by the generator warm-up time setting in the EG4® Monitor Center. After the warm-up period completes, the GridBOSS closes the generator relay. Before the generator shuts down, it must complete its cool-down period. After the cool-down time finishes, the GridBOSS opens the generator relay and Start/Stop Relay 1. The Start/Stop Relay 1 connection is labeled Dry 1 on the GridBOSS cover plate. The Dry 2 connections are currently unused and reserved for future use.

Generator 2-Wire Start Specifications

- Maximum Voltage 30 VDC, 277 VAC
- Maximum NO Contact Current: 5A
- Maximum NC Contact Current: 3A

GridBOSS Communications Board

- COM1 and NC1 are a set of normally closed switches
- COM1 and NO1 are a set of normally open switches
- COM2 and NC2 are a set of normally closed switches
- COM2 and NO2 are a set of normally open switches

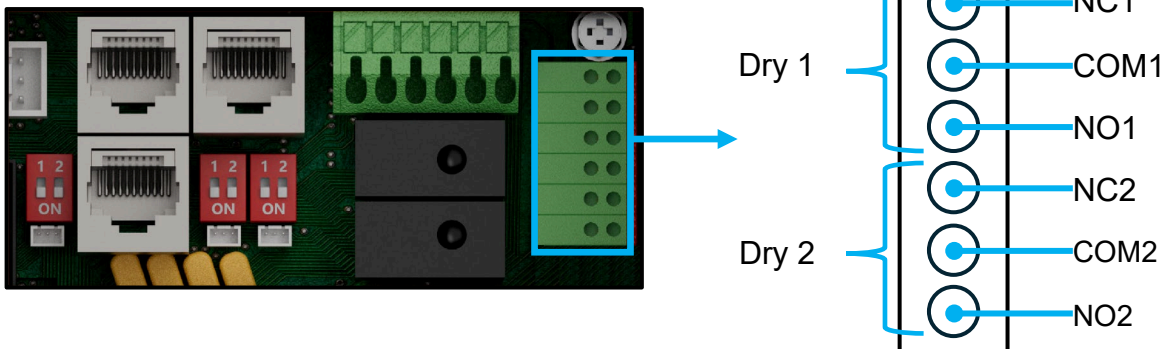

NON-BACKUP LOADS PORT

The non-backup loads port passes power from the grid input to loads that do not require backup or that are intentionally excluded from the backup loads to prevent inverter overload during a grid outage. Loads connected to this port will not receive power during a grid outage. Smart ports may provide a better option for loads that could overload the inverter during startup while still allowing backup operation when sufficient power is available from the inverters during a grid outage.

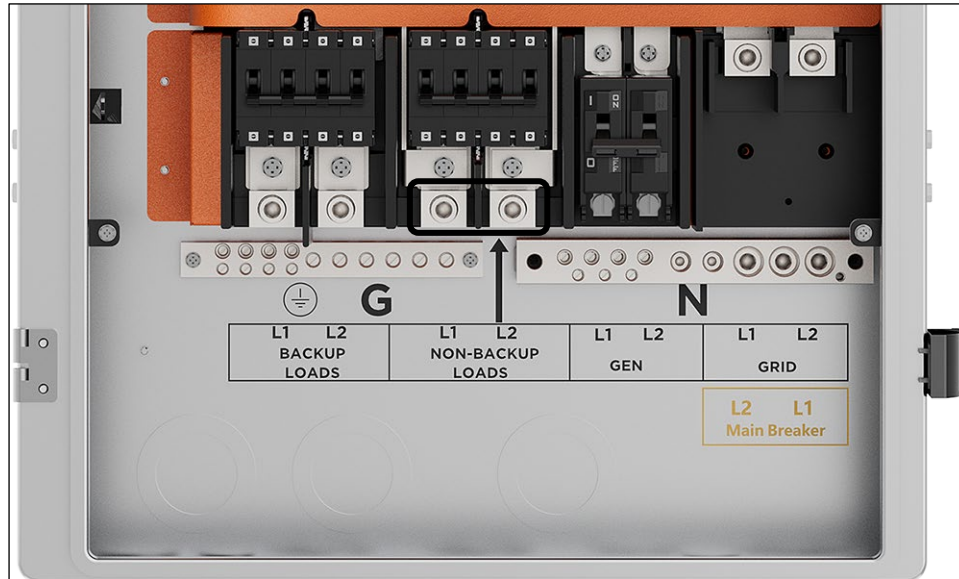

NOTE

The breaker located above the non-backup port is not connected to the non-backup port lugs and is not used by the non-backup port. This breaker functions only when manual bypass mode is activated.



CAUTION

The non-backup port is not controlled by a breaker or relay and will always carry current when the GridBOSS receives grid input.



WARNING

The non-backup port does not include built-in overcurrent protection at the port output. Install an external breaker with the appropriate amperage rating to protect the wire size used. The breaker rating must not exceed 200A.

Refer to the table below for wire size and torque recommendations when connecting the non-backup port wiring.

BREAKER SIZE	MAX. SUPPORTED BREAKER SIZE	SUPPORTED WIRE SIZE	MAX. TORQUE VALUE	TOOL SIZE
Lugs	Lugs only	4 – 2/0 AWG	110 in-lbs. (12Nm)	5/16 in. (8 mm)
		3/0 AWG – 250 kcmil	275 in-lbs. (31Nm)	5/16 in. (8 mm)

BACKUP LOADS PORT

The backup loads port provides power to any panel that needs to be backed up by the EG4® Energy Storage System (ESS). This could be the home's main breaker panel, a critical loads subpanel, or any combination of main panels and subpanels.

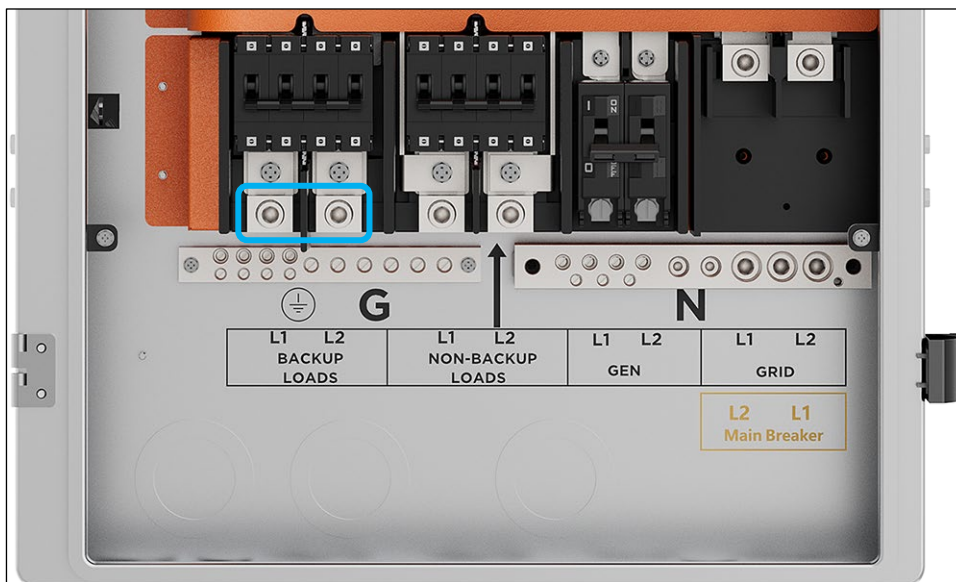

CAUTION

The “backup loads” port cannot connect to a load panel that receives power from another source, such as a utility, generator, or AC-coupled solar system, unless a manual transfer switch is installed.

NOTICE

When operating an EG4 hybrid inverter with the GridBOSS, keep the inverter load port unused and in the OFF position. The inverter grid port supports both input and output based on the inverter settings. Critical loads connect to and receive power from the backup loads port on the GridBOSS.

Refer to the table below for wire size and torque recommendations when connecting the backup port wiring.

MAX. SUPPORTED BREAKER SIZE	SUPPORTED WIRE SIZE	MAX. TORQUE VALUE	TOOL SIZE
200A (preinstalled)	4 – 2/0 AWG	110 in-lbs. (12Nm)	5/16 in. (8 mm)
	3/0 AWG – 250 kcmil	275 in-lbs. (31Nm)	5/16 in. (8 mm)

HYBRID INVERTER PORTS

The GridBOSS hybrid ports support compatible EG4® hybrid inverters. When connecting the AC wiring to the hybrid inverter, connect only the inverter’s grid port to the GridBOSS hybrid port. Refer to the table below for the list of supported EG4 hybrid inverters.

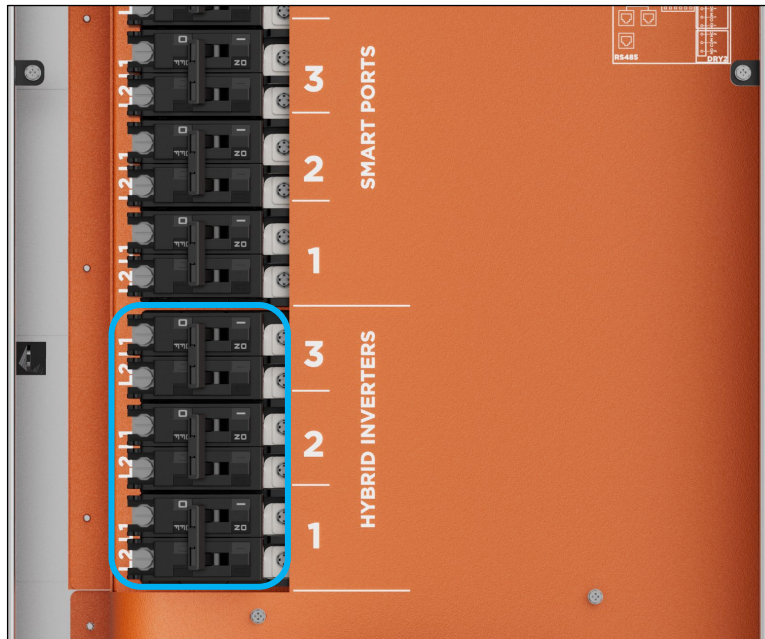

WARNING

- Connect only the 12kPV, 18kPV, FlexBOSS18, and FlexBOSS21 inverters to the hybrid ports. Do not connect any other inverter models, as incompatible connections may damage the inverter connected to the GridBOSS.
- Follow the breaker sizing and wiring requirements specified below for each hybrid inverter. Do not install a breaker with a rating higher than the supported value, as this may result in equipment damage.

NOTICE

When operating a hybrid inverter connected to the GridBOSS, keep the inverter load port unused and in the OFF position. The inverter grid port supports both input and output power based on the inverter’s settings.

Refer to the table below for wire size and torque recommendations when connecting the hybrid port wiring.

HYBRID PORT	SUPPORTED INVERTER MODEL	SUPPORTED BREAKER SIZE	SUPPORTED WIRE SIZE*	TORQUE VALUE
1 – 3	12kPV	50A	6 AWG	use torque value printed on breaker
	18kPV FlexBOSS18	70A	4 AWG	
	FlexBOSS21	90A	2 AWG	

*Size wire according to breaker amperage/system needs

SMART PORTS

Smart ports power smart loads or accept AC-coupled inverter inputs. An internal relay, configured through the EG4® Monitor Center, controls each port. Each port also supports manual operation through its associated breaker, allowing the port to switch on or off. Every smart port is configured individually and has distinct load specifications, as listed in the table on the next page.

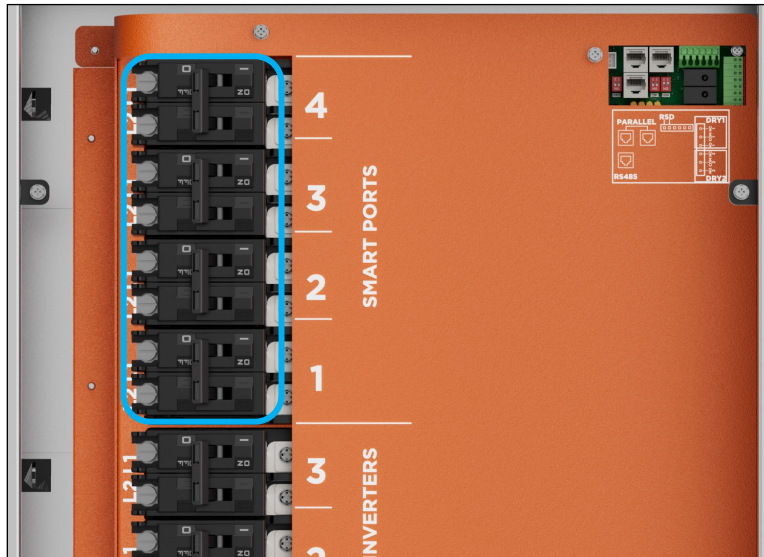

When smart ports are configured for smart loads, the connected devices operate based on grid presence, Time of Use (TOU) settings, battery State of Charge (SOC) or voltage, and PV status. When a smart port connects to an AC-coupled inverter, the PV array connected to the inverter can inject additional power into the ESS system.



NOTE

When operating a hybrid inverter with the GridBOSS, smart port functionality transfers from the hybrid inverter to the GridBOSS. Connect all devices that use a smart port directly to a GridBOSS smart port. Select GridBOSS in the EG4 Monitor Center during smart port configuration.

Refer to the table below for wire size and torque recommendations, which vary depending on the type of wire and connection.

SMART PORT #	SUPPORTED BREAKER SIZES	SUPPORTED WIRE SIZE*	MAX TORQUE VALUE
1	90A, 100A, 125A	2 – 2/0 AWG	use torque value printed on breaker
1 & 2	70A, 80A	4 – 3 AWG	
1 – 4	30A, 40A, 50A, 60A	10 – 4 AWG	

*Size wire according to breaker amperage/system needs

RAPID SHUTDOWN & ESS DISCONNECT

The GridBOSS supports a rapid shutdown system that complies with NEC 690.12 (2017 and 2020) requirements, as well as an ESS Disconnect that complies with NEC 706.15. When activated, the rapid shutdown switch located on the right side of the GridBOSS initiates a complete system shutdown, including the inverters, backup loads, smart ports, supported batteries, and PV system (when properly equipped). The non-backup loads port remains the only port that continues to receive power from the grid. When connecting the GridBOSS to EG4® hybrid inverters, connect the RSD wiring only to the master inverter. Install an external RSD/ESS initiator inline between the inverter and the GridBOSS, as shown in the image below.

NOTE

When supported, EG4 batteries operate in closed-loop communication with the inverter; activation of RSD also initiates the ESS Disconnect.

The system can incorporate an external RSD/ESS initiator (switch) installed near the service entrance and in clear view of first responders. When an external RSD/ESS initiator is installed in series with the GridBOSS-to-inverter wiring, use normally closed contacts for emergency shutdown.

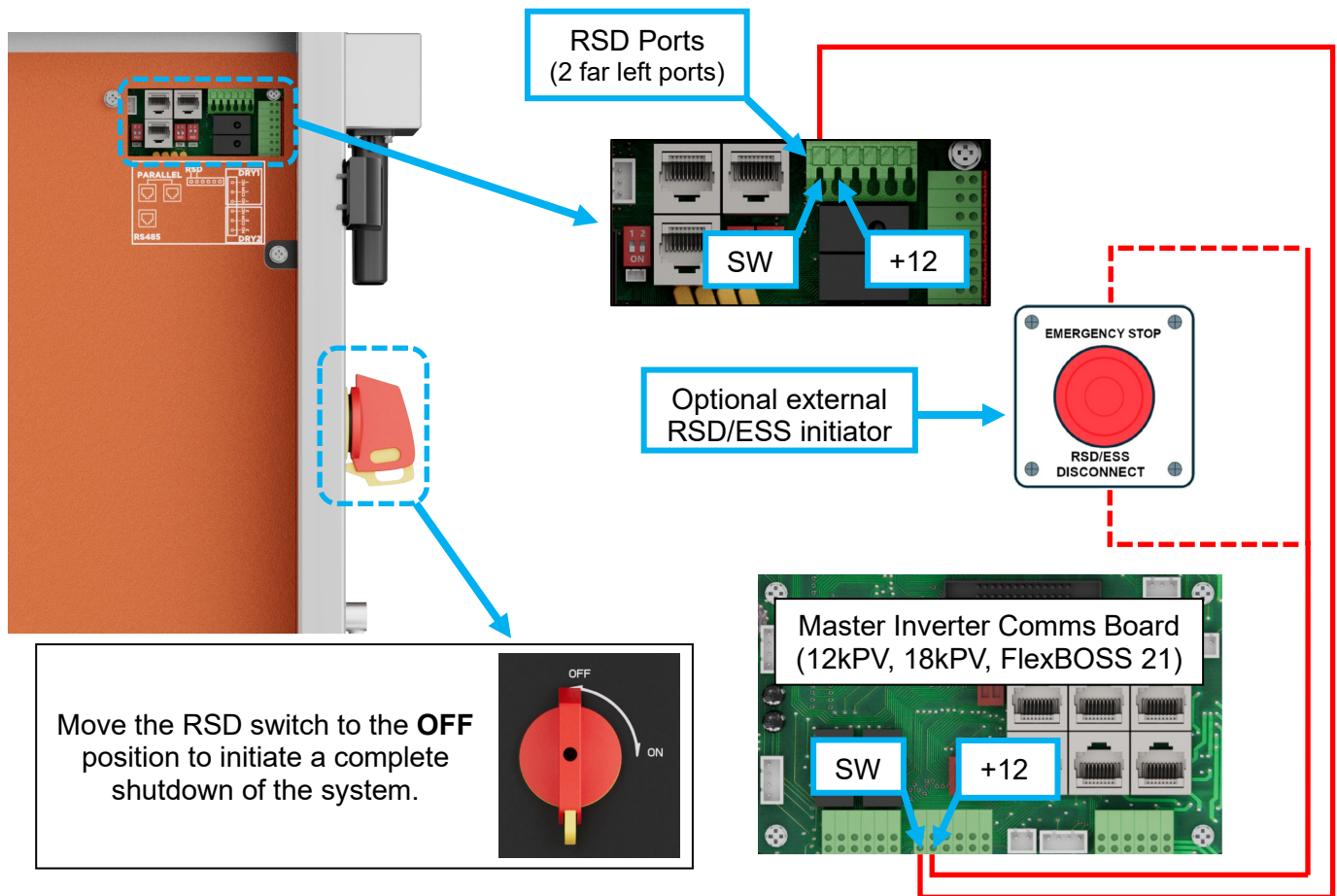

Refer to the Hybrid Inverter RSD Wiring Guide for more information.

If installed, remove the existing jumper wire between the SW and +12 ports on the master inverter only. All subsequent inverters must have the jumper installed.

REPLACE THE CABLE BOX COVER

Before reinstalling the cable box cover, remove any knockouts where breakers have been installed. Remove each knockout by rocking it back and forth until the small connection point between the knockout and the cover breaks, allowing the knockout to detach. Install the grid and generator cover plates if breakers are not installed in those positions. After completing these steps, reinstall the cable box cover before powering up the unit. The image below shows all hybrid and smart port breakers fully populated. No main or generator breakers are present, so the cover plates are secured to the cable box cover.

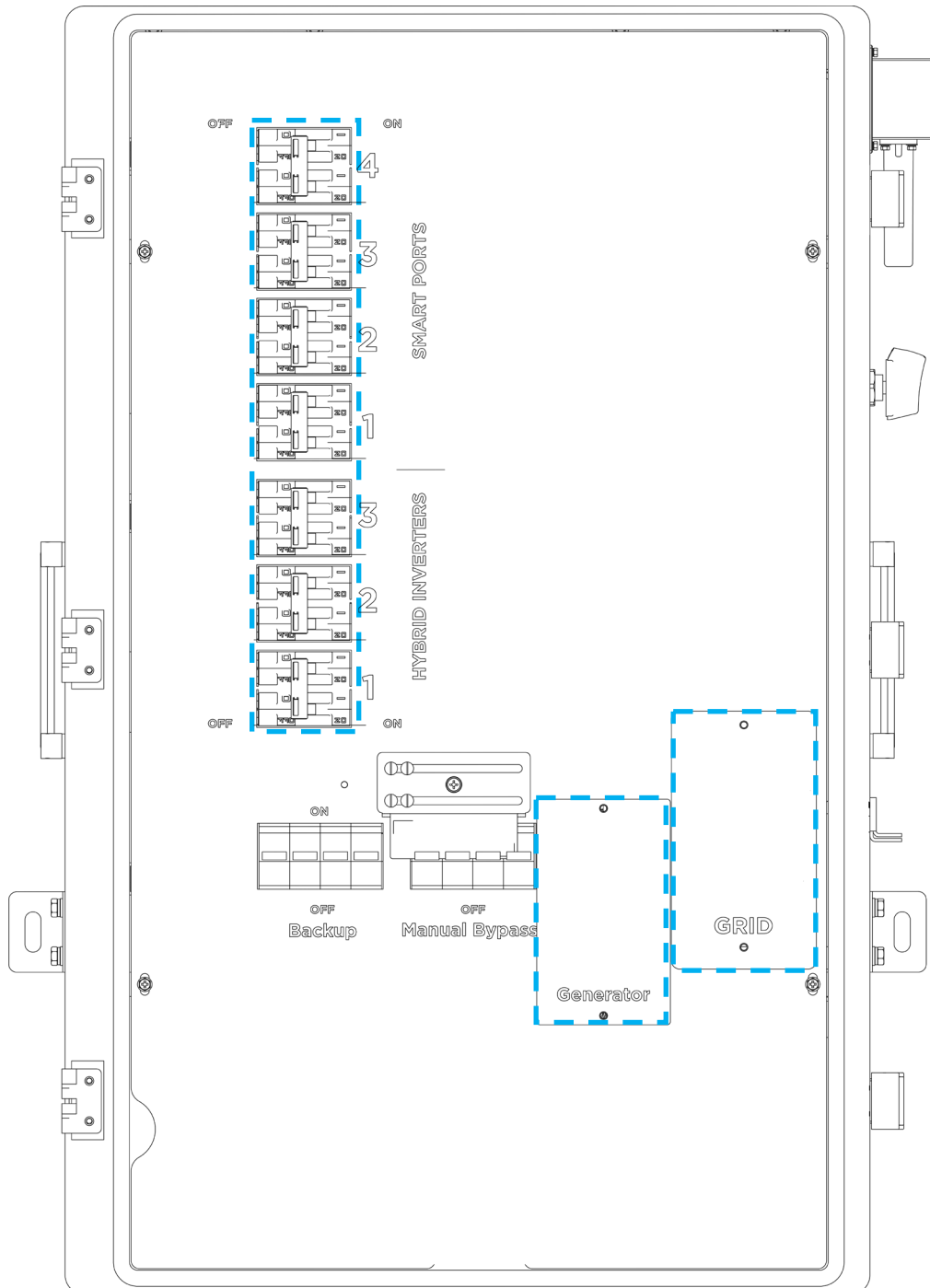

7.6 CONFIGURE THE HYBRID INVERTERS

As a best practice, configure the hybrid inverter(s) before configuring the GridBOSS. During inverter configuration, note the following:

- During the initial configuration, operate the inverters using battery power only. Keep the GridBOSS powered off. The inverter grid port must not connect directly to the grid.
- Do not install the inverter CT clamps, as the GridBOSS includes internal CT clamps.
- Confirm proper connection and operation of the battery or battery bank and the PV array with the inverter(s).
- When using multiple inverters, confirm that they operate in a functioning parallel configuration.
- **DO NOT** connect the inverter load port to the GridBOSS. Keep the inverter load port in the OFF position.
- **DO NOT** connect any device to the inverter generator port (if equipped). Keep the generator breaker in the OFF position. Configure all smart load, AC coupling, and generator functionality through the GridBOSS.
- Install at least the minimum required firmware version on each inverter, as listed in the chart below.

Refer to the inverter documentation linked below for detailed installation and configuration guidance:



**12kPV
Inverter**



**18kPV
Inverter**



**FlexBOSS18
Inverter**



**FlexBOSS21
Inverter**



NOTE

Verify that each hybrid inverter has at least the minimum required firmware installed to support connectivity with the GridBOSS. Each inverter uses system firmware. The 12kPV and 18kPV models also use LCD firmware, which supports the front-panel LCD screen. For additional information on firmware updates, refer to Section 10 of this manual.

INVERTER	MIN. SYSTEM FIRMWARE	MIN. LCD FIRMWARE
12kPV	FAAB-1E1E	V18
18kPV	FAAB-1E1E	V18
FlexBOSS18	FAAB-2021	N/A
FlexBOSS21	FAAB-1E1E	N/A

7.7 CONFIGURE GRIDBOSS

Before configuring the GridBOSS, verify the following:

- The inverter(s) are fully configured with at least the minimum firmware required to operate with the GridBOSS, as completed in the previous section.
 - Each hybrid inverter is powered **OFF**.
 - All GridBOSS breakers are in the **OFF** position.
 - If a main breaker is not installed in the GridBOSS, place the power source supplying the GridBOSS in the OFF position.
 - If the non-backup port connects to an electrical panel, place the corresponding panel breaker in the OFF position. **DO NOT** switch on the electrical panel's main breaker until the GridBOSS configuration is complete.
 - Before proceeding with the steps below, use a multimeter to confirm that no voltage or current is present at any GridBOSS lug or breaker.
1. Connect the communication cable between the GridBOSS and the inverter(s) using the images below as reference.
 - The GridBOSS DIP switches remain in the down position (ON) as shipped from the factory. Also, note that the GridBOSS DIP switch is flipped 180 degrees compared to the inverters. Down is ON and up is OFF.
 - For a single inverter or the master inverter, set the DIP switches to the up position (ON).
 - Set the DIP switches of all slave inverters to the down position (OFF).



NOTE

If replacement or extension of the communications cable is required, use a CAT5 or higher specification straight-through network cable in the 568B format. The maximum supported cable length is 260 feet (80 meters).

GridBOSS with One Hybrid Inverter

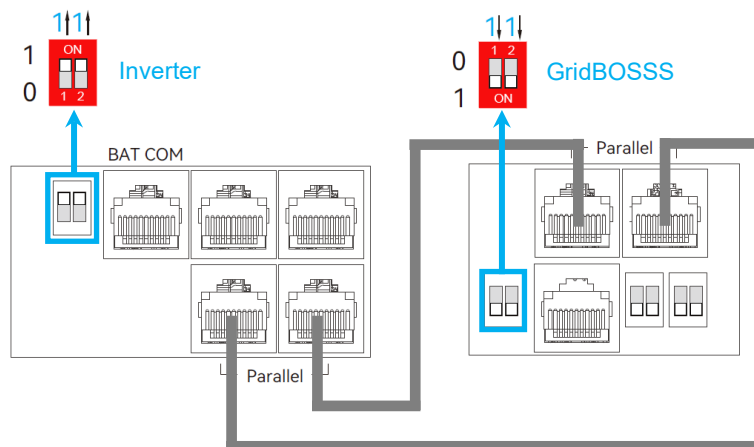

GridBOSS with Two Hybrid Inverters

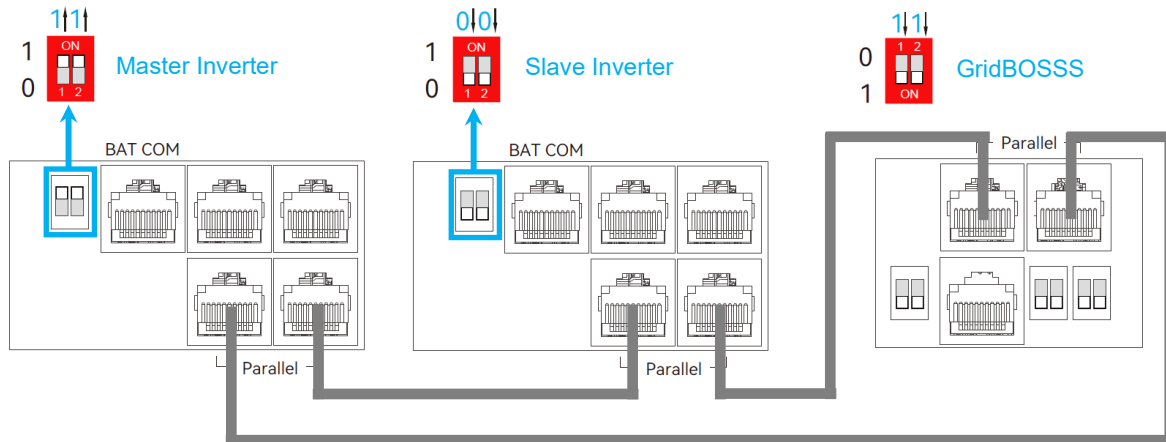

GridBOSS with Three Hybrid Inverters

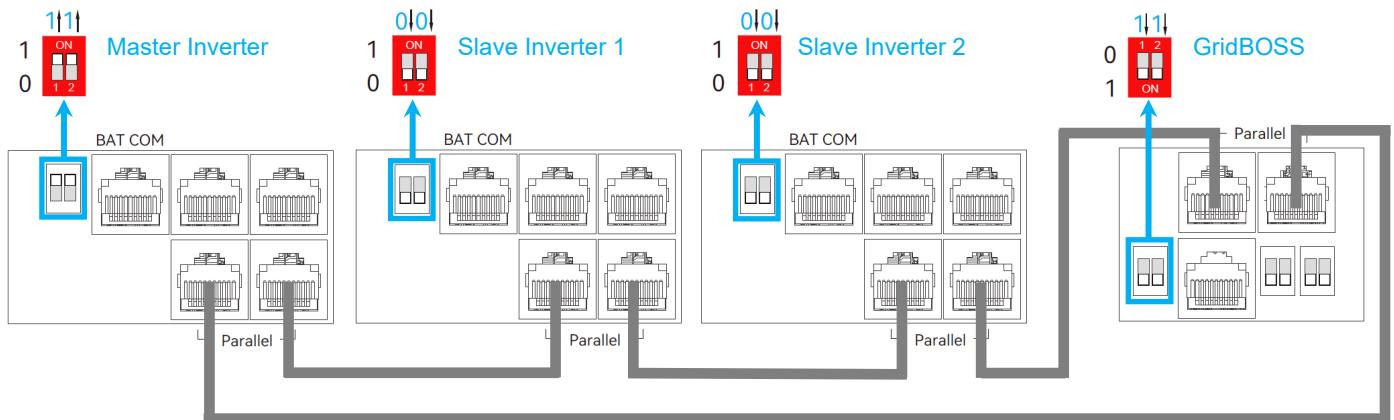

2. Power on the inverter(s), starting with the master in a parallel configuration. The inverters should only be powered by a battery or battery bank.
3. Enable the “Grid Boss” setting on the inverter (master inverter in a parallel configuration). The 12kPV and 18kPV can be configured using their front LCD panels. When setting up the FlexBOSS inverters, use the EG4® Monitor Center website or the optional EG4 FlexBOSS Screen Kit (sold separately).
 - LCD Panel: Navigate to the Advanced page and select the “Grid Boss” setting, and then select the “Set” button to save the settings.

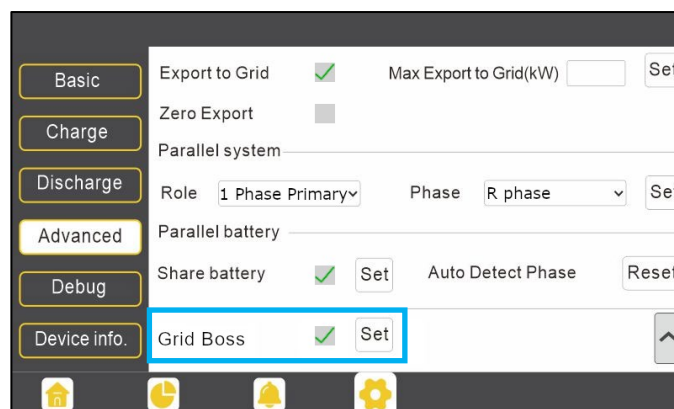

- **Monitor Center:** Select the “Maintenance” tab and then choose “Working Mode” from the upper-right area of the screen. Expand “Application Setting” and then select “Advanced Settings.” Select “Enable” next to the “Grid Boss Enable” setting.

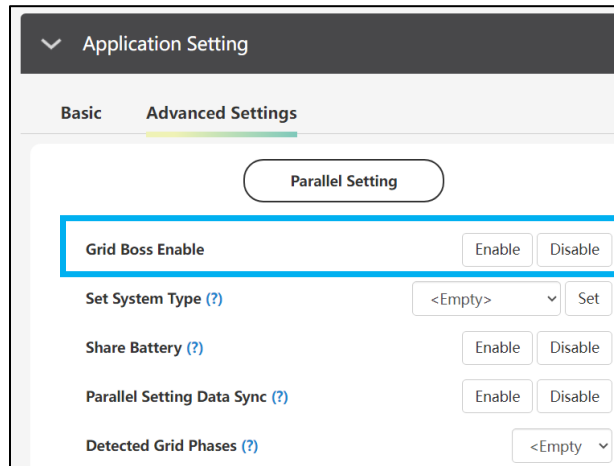

4. Switch the GridBOSS hybrid inverter breaker(s) to the ON position. This action powers on the GridBOSS using the inverter’s grid port as the power source. The GridBOSS will not power on if the “Grid Boss Enable” setting remains disabled.
5. Verify that the GridBOSS hybrid LED is illuminated and displays a solid green light.
6. Verify that all grid settings are configured appropriately based on whether grid sell-back is enabled or disabled. All grid sell-back functionality is configured within the inverter settings. The FlexBOSS inverters require configuration through the EG4 Monitor Center, mobile app, or an external EG4 FlexBOSS Screen Kit.
7. Enable grid input to the GridBOSS by turning on the grid breaker (if equipped) or the breaker providing grid access.

7.8 VERIFY CONFIGURATION

1. Visually inspect the GridBOSS’ front panel LEDs. The “Grid” and “Hybrid” LEDs should be solid green. If a flashing LED is present, refer to Section 11 for additional troubleshooting information.
2. Verify inverter settings using the LCD or Monitor Center:

Using the LCD Panel:

Verify the settings shown below using the inverter’s LCD panel. The inverter also displays a small green “Grid Boss” icon in the bottom-left corner of the home screen.

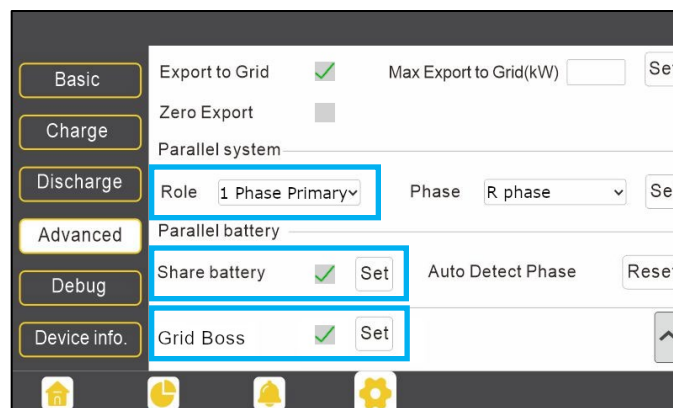

- **Role:** Verify that the GridBOSS has only one master inverter. Set the master inverter to “1 Phase Primary”, and set all other inverters to “Slave.” Press the “Auto Detect Phase” reset button after any changes to the parallel settings.
- **Share Battery:** Select “Share Battery” when the inverters share a single battery bank. Do not select “Share Battery” when each inverter connects to a dedicated battery.
- **Grid Boss:** Verify that “Grid Boss” is selected for all parallel inverters connected to the GridBOSS hybrid ports.



NOTE

When a 12kPV or 18kPV inverter connects to the GridBOSS, the inverter’s main LCD page displays total power values for the entire system. These values differ from those shown in parallel systems operating without the GridBOSS. On the main page, “Grid Power” reflects the GridBOSS grid power value. “Home Load” represents the total load power passing through the GridBOSS. “AC Couple” power represents the combined power of all AC-coupled smart ports.

Using Monitor Center:

Select the “Maintenance” tab, then select “Working Mode” in the upper-right area of the screen. Expand “Application Setting”, then select “Advanced Settings.” Next to the “Grid Boss Enable” setting, select “Enable.”

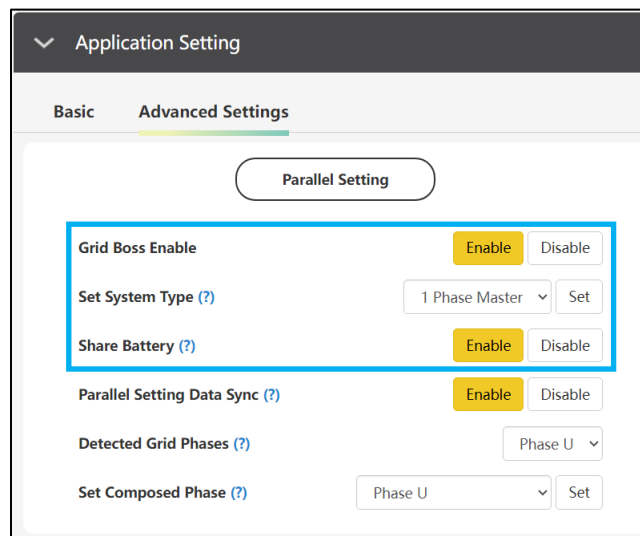

- **Grid Boss Enable:** Verify “Grid Boss Enable” is enabled for each inverter connected to a GridBOSS hybrid port.
 - **Set System Type:** Verify that GridBOSS has only ONE master inverter. The master inverter should be set to “1 Phase Master,” and all other inverters should be set to “Slave.”
 - **Share Battery:** Select “share battery” if the inverters share a single battery bank. Do not select “share battery” if each inverter is connected to a dedicated battery.
3. Check each inverter and verify there are no errors or warnings. If there are any issues, refer to the inverter model documentation for additional troubleshooting information.
 4. The system is ready for use and can be further configured with advanced features such as auto generator start, smart loads, and AC coupling.

8. SYSTEM OPERATION & CONFIGURATION EXAMPLES

To power up and become ready for operation, the GridBOSS requires configuration with at least one powered input. The input can originate from the grid, a hybrid inverter, or a generator. The GridBOSS functions as a power distribution unit, controlling power flow through internal relays and software. When configuring settings for the inverters or the GridBOSS, select the corresponding serial number in the EG4® Monitor Center or the mobile app.

8.1 HYBRID INVERTERS

When hybrid inverters operate with GridBOSS, grid interactivity settings are configured at the inverter level. The GridBOSS controls only the ports within the chassis by opening or closing each individual port relay. The inverters communicate with the GridBOSS through a communication cable, exchanging configuration settings, currents, voltages, and other required data to manage power output.

NO GRID SELL BACK

In this example, “Grid Sell Back” is disabled in the inverter’s settings. This configuration supports grid assist for powering backup loads, smart loads, charging battery storage, and supplying non-backup loads.

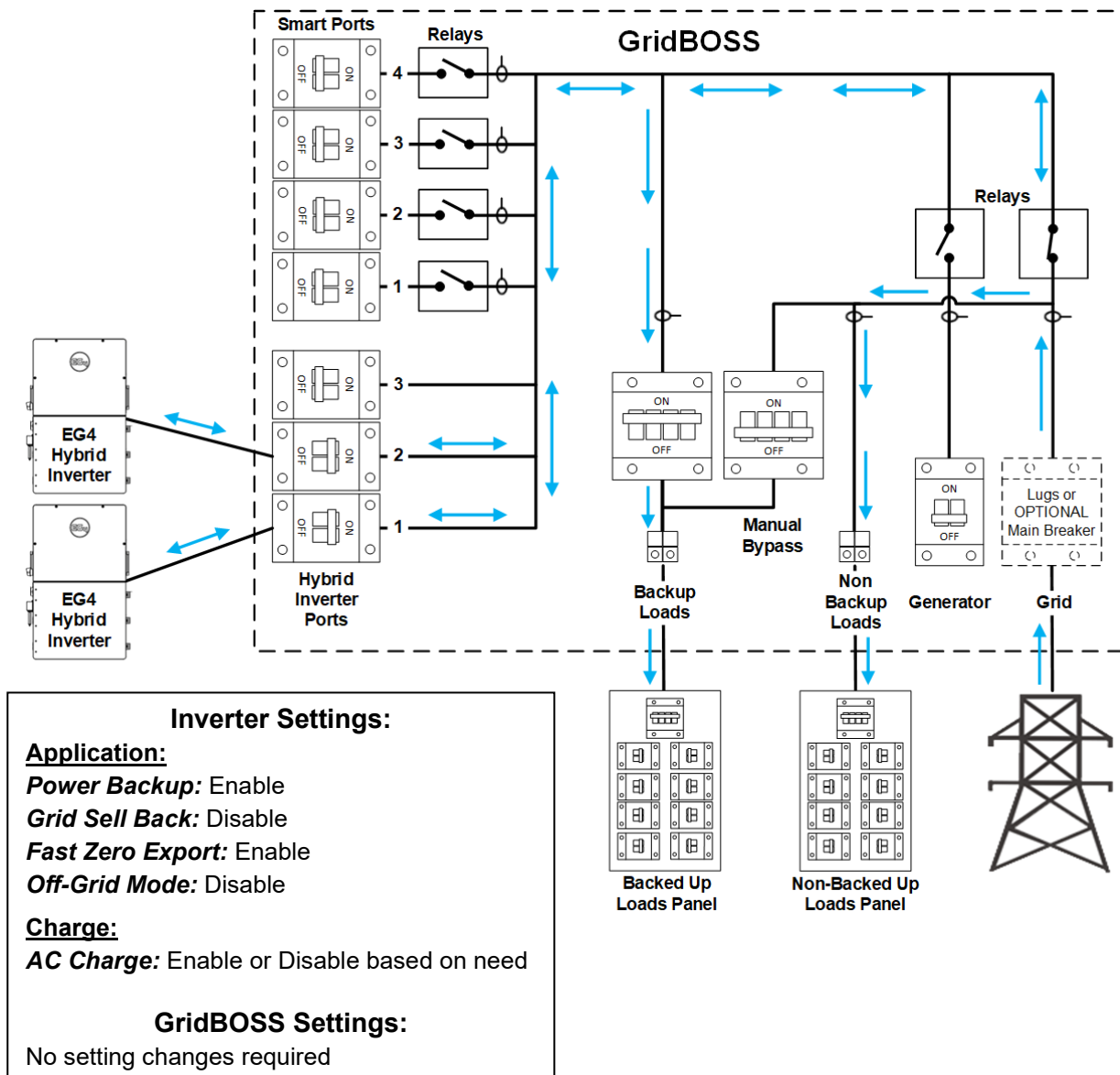

GRID SELL BACK

In this example, “Grid Sell Back” is enabled in the inverter settings. When the inverter supplies power to the loads, backup loads receive priority, and any excess power is allocated to non-backup loads. Power is also supplied to the smart loads, with priority determined by the smart load settings. To include battery power in grid sell-back, enable “Forced Discharge Enable.” Enable “PV Sell To Grid (Comp. w/ NEM3.0)” to allow only PV power for grid sell-back. To maximize grid sell-back, consider shedding non-critical loads using the smart ports. The grid assists in supplying power to non-backup loads, backup loads, and the smart ports as required.

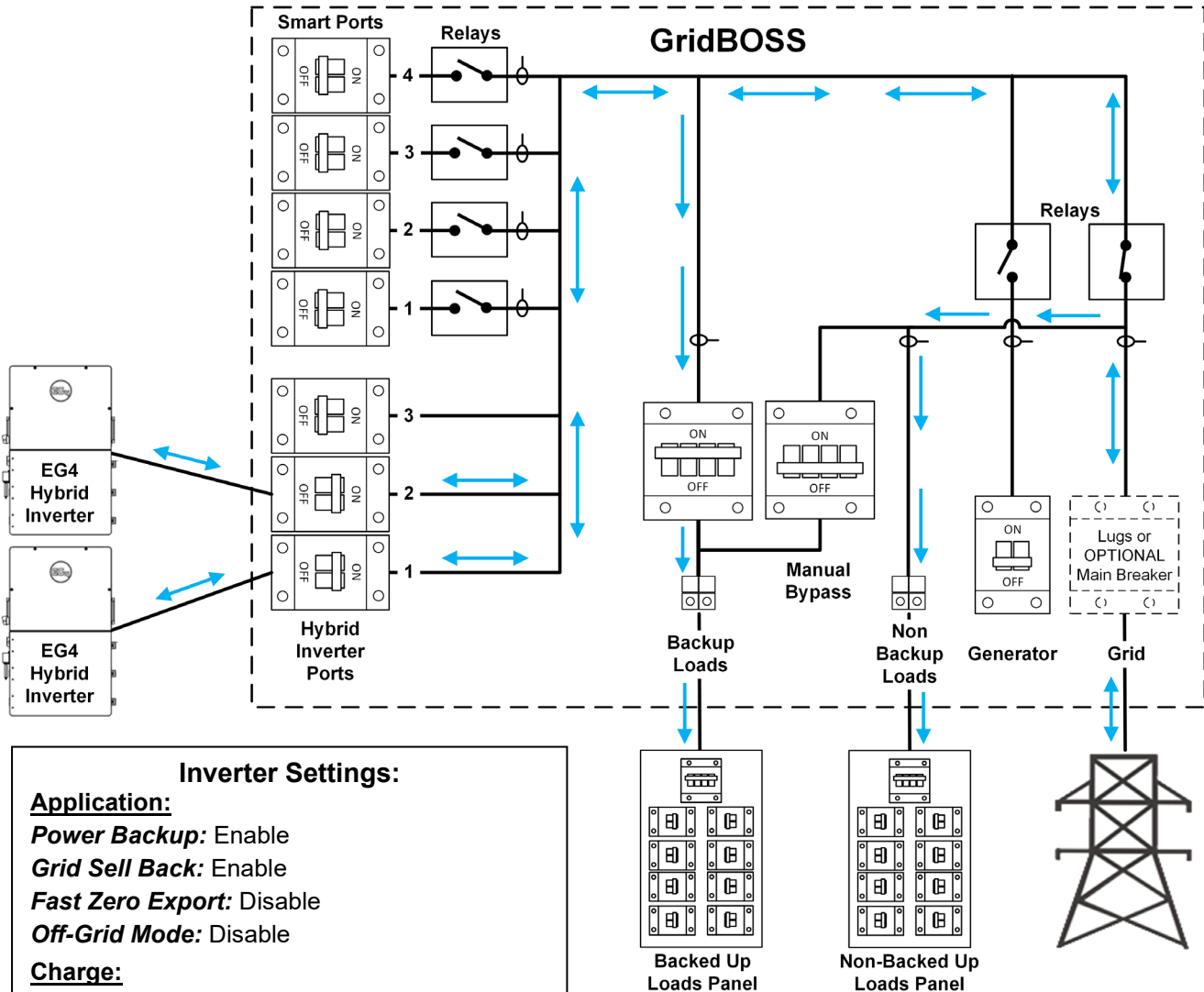

Inverter Settings:

Application:
Power Backup: Enable
Grid Sell Back: Enable
Fast Zero Export: Disable
Off-Grid Mode: Disable

Charge:
AC Charge: Enable or Disable based on need

Discharge:
Forced Discharge Enable: Disable
PV Sell To Grid (Comp. w/ NEM3.0): Enable

GridBOSS Settings:
 No changes required

OFF-GRID MODE

In this example, the inverter's "Off-Grid Mode" is enabled. The inverter(s) power the backup and smart loads. The grid does not provide supplemental power to the backup or smart loads but can charge the battery when AC charging is enabled. When AC charging is active, the main grid relay closes. The non-backup loads receive power only from the grid.

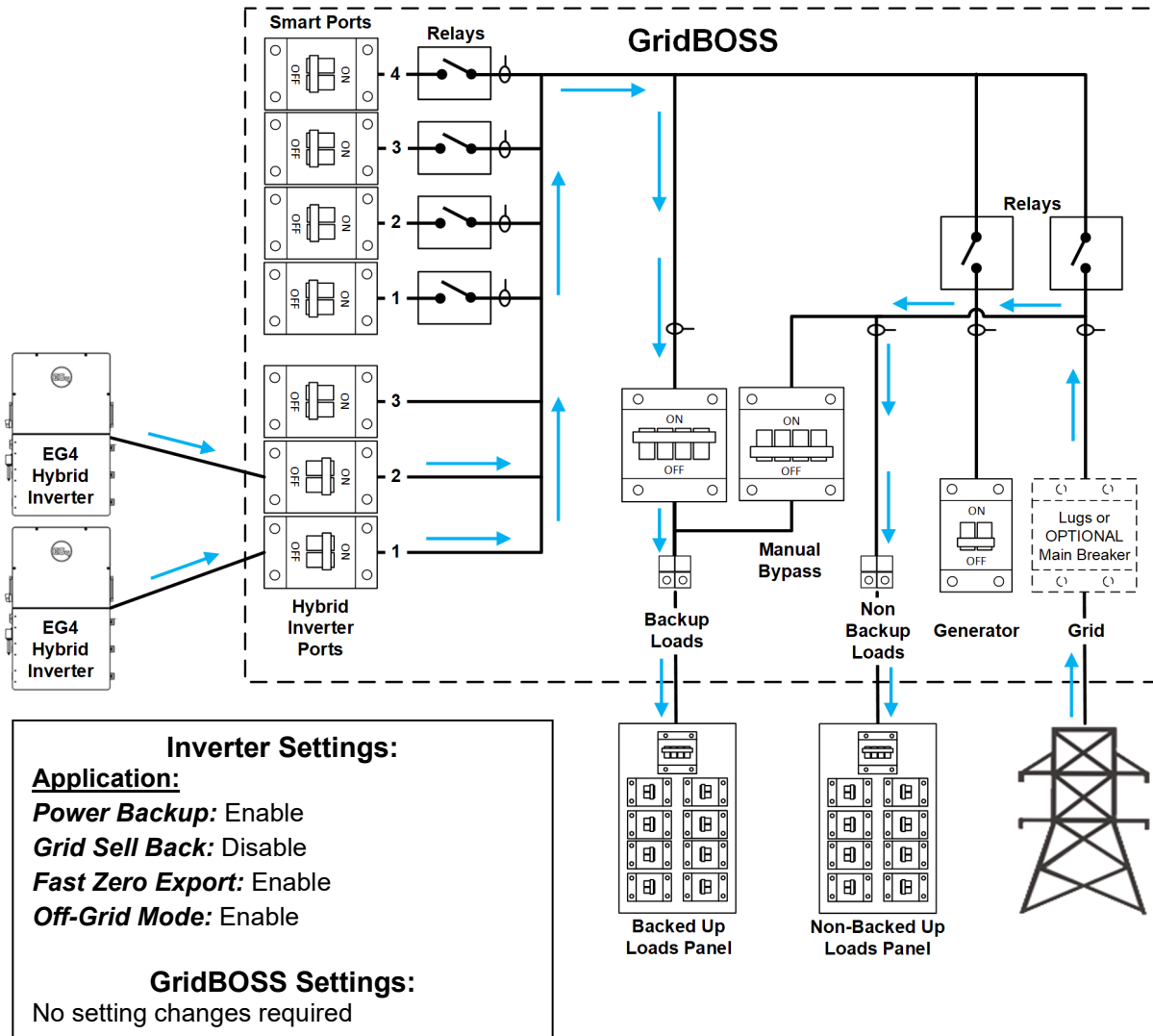

8.2 GENERATOR

In this example, a generator connects to the GridBOSS to power the backup loads and supplement battery charging when required. The generator breaker and relay close, allowing current to flow to the backup loads. Generator output can assist in charging the batteries when the appropriate settings are configured, and the loads remain low enough for the generator's additional power to charge the batteries. If a small generator cannot fully power the critical loads, enable "Generator Boost" at the inverter. Proper connection of the generator start/stop wiring supports generator start and stop functionality. The smart ports in the example below do not receive current unless configured for operation in the EG4® Monitor Center.

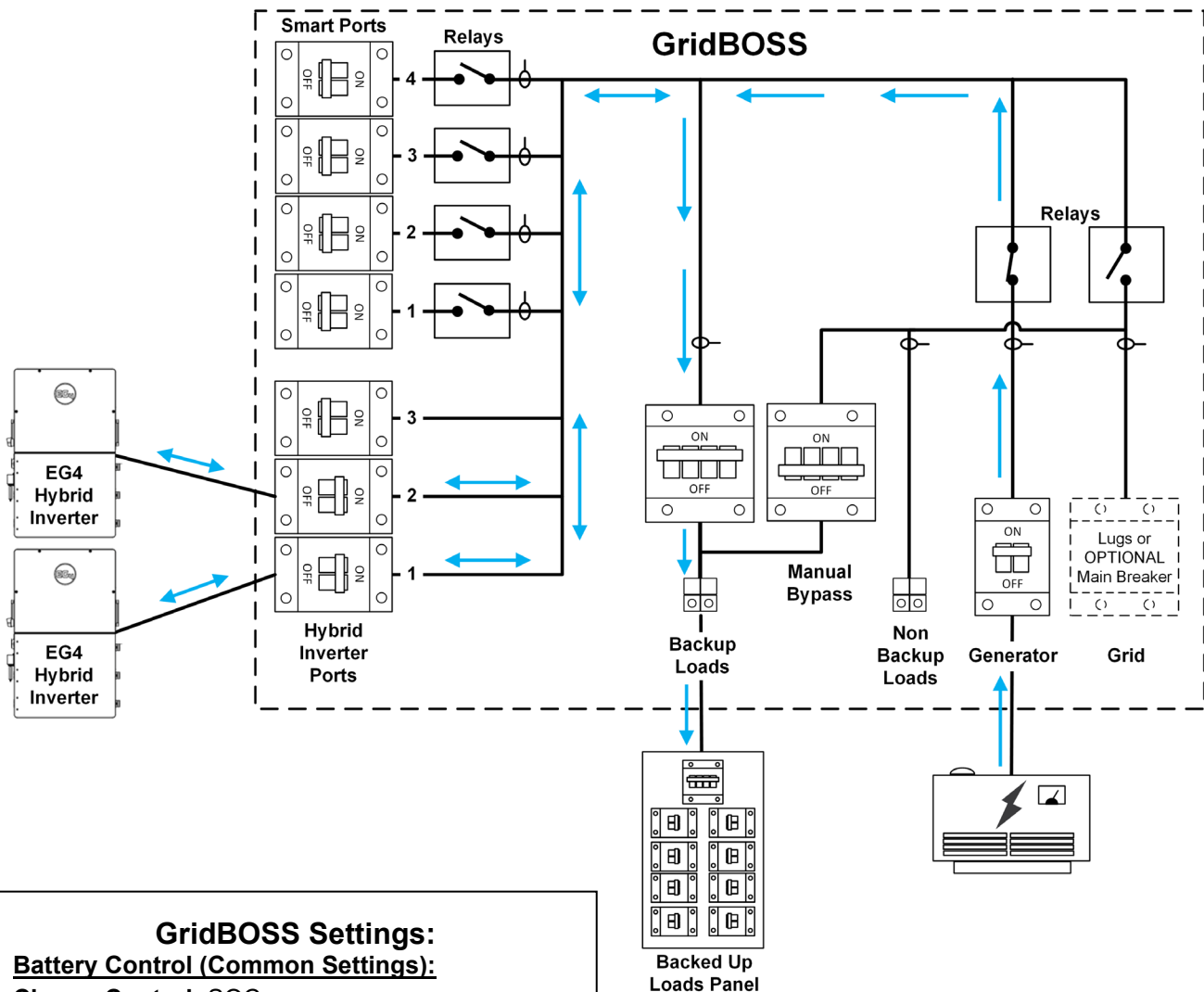

GridBOSS Settings:

Battery Control (Common Settings):

Charge Control: SOC

Discharge Control: SOC

GENERATOR:

Generator SOC/Vbat Enable: Enable

Batt Charge Current Limit (Acd): 250

Gen Rated Power (kW): 25.5

Charge Start SOC: 50%

Charge End SOC: 80%

Generator Warm Up Time(s): 120

Generator Remote Auto Turn off time(m): 20

Inverter Settings:

Application:

Grid Sell Back: Enable or Disable

Fast Zero Export: Disable or Disable

Off-Grid Mode: Disable or Disable

Charge:

AC Charge: Enable or Disable

Generator Charge:

Generator Boost: Enable or Disable

8.3 MANUAL BYPASS MODE

In this scenario, all relays in the GridBOSS are bypassed, allowing grid current to flow directly to the backup loads port and power the critical loads panel. Bypass mode supports critical loads in the event that the GridBOSS requires bypassing. The non-backup loads port also receives power from the grid when the system operates in manual bypass mode.

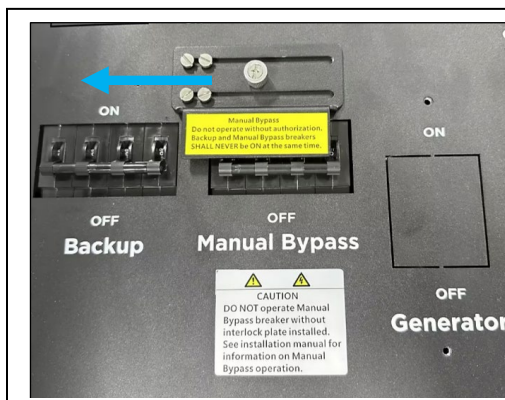
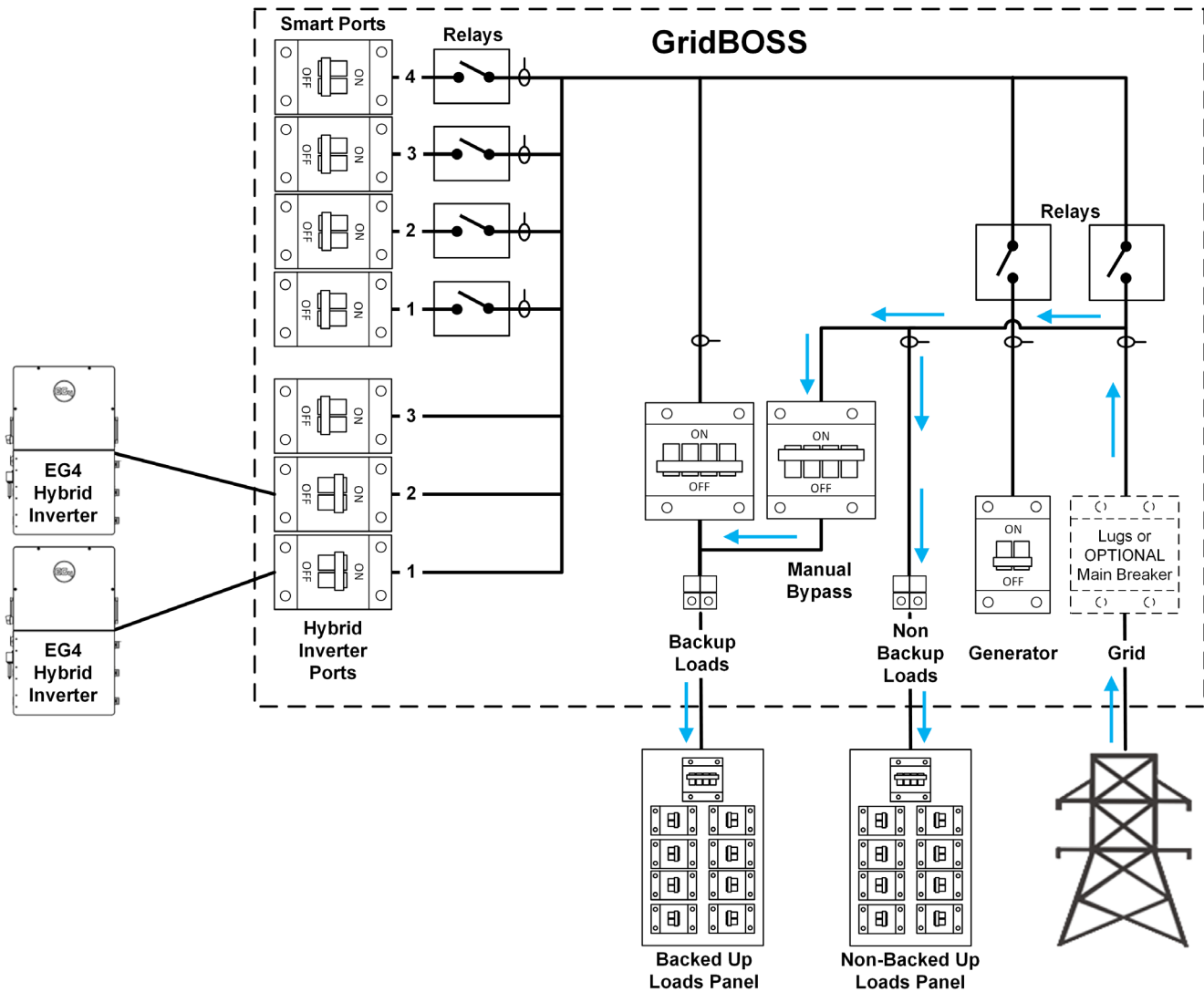

To enable manual bypass:

1. Set the "Backup" load breaker to the off position.
2. Slide the manual bypass interlock all the way to the left.
3. Set the "Manual Bypass" breaker to the on position.

8.4 SMART LOADS

In this scenario, a water heater and an electric vehicle charger connect to smart ports 2 and 3. Multiple configuration options for a smart port are available through the EG4® Monitor Center, and this section describes several of these methods. The first option allows manual configuration to keep the port always on or always off. The second option enables the port to turn on or off based on battery SOC and/or defined time periods. Another option uses load shedding, which adds a setting based on the PV input level.



NOTE

Smart port functionality at the hybrid inverter is not supported when connected to a GridBOSS. All devices powered by a smart port must connect directly to a GridBOSS smart port.

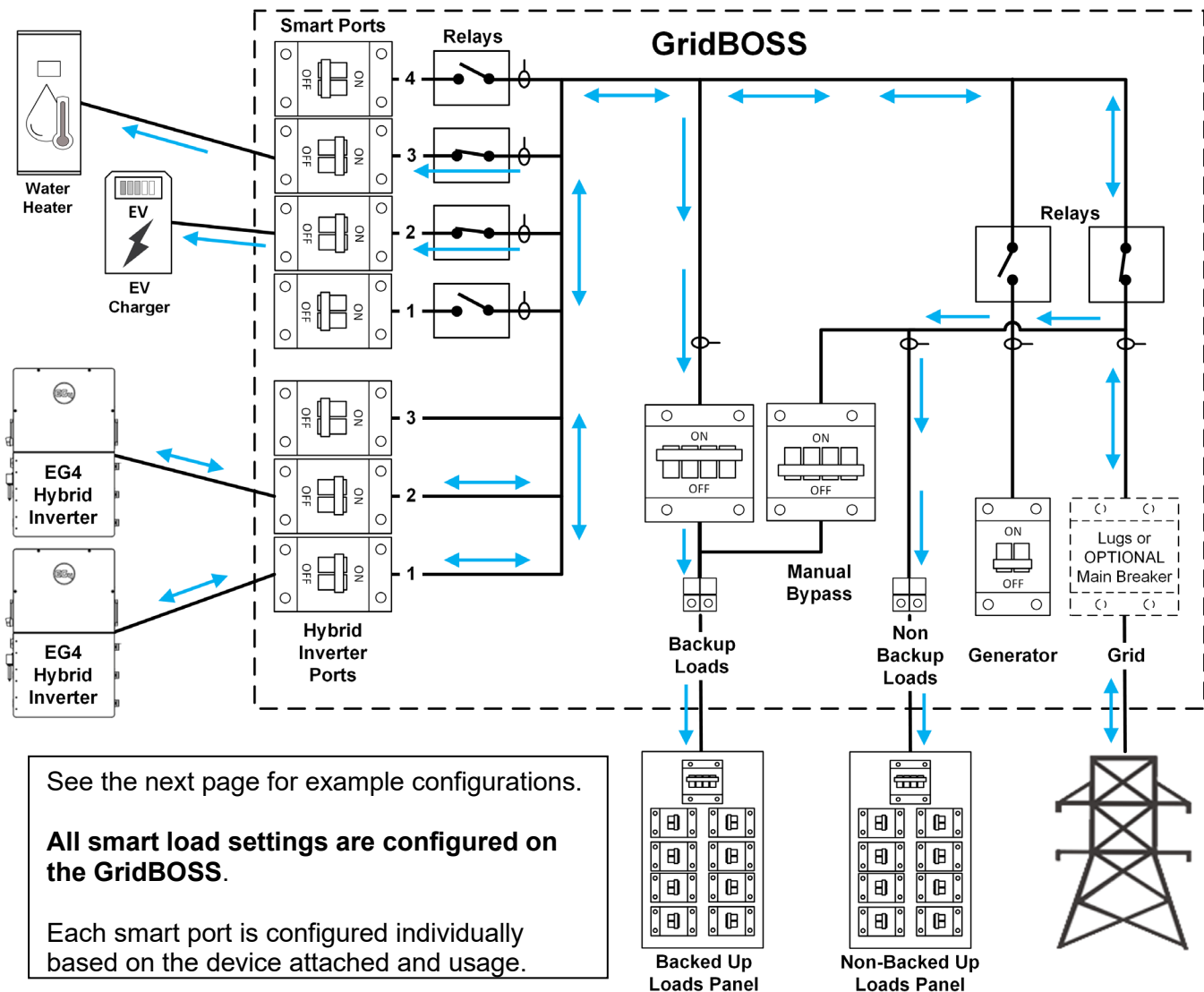

Example Configurations:

1. **Always Powered On:**

Two options allow a smart port to remain continuously enabled. The first option activates the smart port when the GridBOSS detects an active grid connection by using the “Grid Always On” feature. If the grid goes down, the smart port relay opens and the smart port stops supplying power to the connected load. The inverter must not operate in Off-Grid mode, as this mode prevents the smart port from activating when the grid is present.

Battery Control (Common Settings):

Charge Control: SOC

Discharge Control: SOC

Grid Boss Smart Port #:

Smart Port Mode: Smart Load

Smart Load Enable: Enable

Smart Load Grid Always On: Enable

The second option uses time-based settings to enable the smart port for 24 hours, eliminating the need for grid input. In off-grid configurations, maintaining power to a smart port requires a large battery bank and a photovoltaic (PV) array capable of quickly recharging the battery bank. To prevent the smart port load from depleting battery capacity and potentially causing the inverter to shut down, configure the smart port to power off when the battery’s SOC falls below a defined level using the “Smart Load End SOC” setting. In the example below, the smart port operates for a 24-hour period only when the battery’s SOC remains above 40%.

Battery Control (Common Settings):

Charge Control: SOC

Discharge Control: SOC

Grid Boss Smart Port #:

Smart Port Mode: Smart Load

Smart Load Based On: Time + SOC

Smart Load Enable: Enable

Smart Load Grid Always On: Disable

Smart Load Start Time: 00:00

Smart Load End Time: 23:59

Smart Load End SOC(%): 40%

2. **Time + SOC or SOC:** A smart port can be enabled based on a defined time period, battery SOC, or a combination of both. In the left example on the next page, the smart port operates between 10:00 a.m. and 6:00 p.m. when the battery SOC remains above 30%. The example on the right activates the smart port when the battery SOC exceeds 70% and disables it when the SOC falls below 30%.

Battery Control (Common Settings):

Charge Control: SOC

Discharge Control: SOC

Grid Boss Smart Port #:

Smart Port Mode: Smart Load

Smart Load Based On: Time + SOC

Smart Load Enable: Enable

Smart Load Grid Always On: Disable

Smart Load Start Time: 10:00

Smart Load End Time: 18:00

Smart Load End SOC(%): 30%

Battery Control (Common Settings):

Charge Control: SOC

Discharge Control: SOC

Grid Boss Smart Port #:

Smart Port Mode: Smart Load

Smart Load Based On: SOC/Volt

Smart Load Enable: Enable

Smart Load Grid Always On: Disable

Smart Load Start & End SOC(%): 70% and 30%

PV + SOC: This example uses PV input as a factor in determining when the smart port is enabled or disabled. The smart load activates when PV input reaches at least 1600 W and the battery SOC remains above 70%. The smart load deactivates when PV input drops below 1600 W or when the battery SOC falls below 30%.

Battery Control (Common Settings):

Charge Control: SOC

Discharge Control: SOC

Grid Boss Smart Port #:

Smart Port Mode: Smart Load

Smart Load Based On: SOC/Volt

Smart Load Enable: Enable

Smart Load Use Shedding Mode: Enable

Smart Load Power Shedding Start PV Power(W): 1600

Smart Load Power Shedding Start & End SOC(%): 70% and 30%

8.5 AC COUPLING

In this scenario, the existing AC-coupled PV connects to smart port 1. Although smart port 1 is used in this example, any smart port can be configured for AC coupling. The additional power generated by the AC-coupled PV can support various loads within the system. Refer to the example configurations on the following page for additional details.

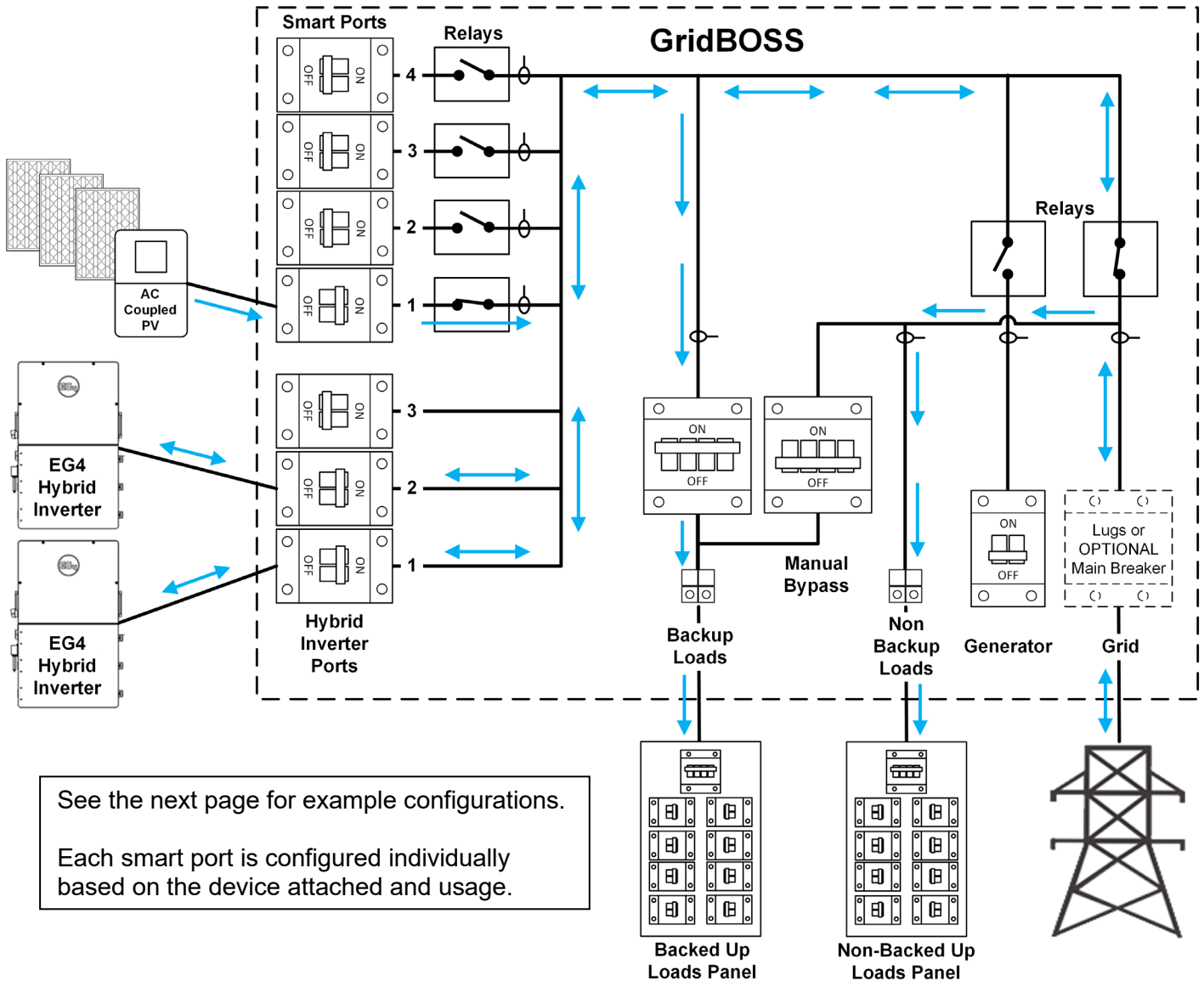

WARNING

Confirm that the AC-coupled device complies with UL1741, UL1741SA, or UL1741SB standards. Devices that lack these certifications may damage the equipment hardware.

NOTE

Smart port functionality at the inverter generator port is not supported when the inverter connects to a GridBOSS. All AC-coupled devices must connect directly to a GridBOSS smart port.

Example Configurations:

Grid Sell Back: In this example, the inverter operates with grid sell-back enabled. AC coupling provides supplemental power to the backup port, smart loads, and the non-backup port, while also assisting with battery charging. After the batteries reach full charge, AC-coupled power continues to support load operation. This configuration operates only when grid input is present.

<p style="text-align: center;">GridBOSS Settings:</p> <p><u>Battery Control (Common Settings):</u> Charge Control: SOC Discharge Control: SOC</p> <p><u>Grid Boss Smart Port #:</u> Smart Port Mode: AC Couple AC Couple Enable: Enable AC Couple Start & End SOC%: 30% & 100% AC Couple Start Time: 00:00 AC Couple End Time: 23:59</p>

<p style="text-align: center;">Inverter Settings:</p> <p><u>Application:</u> Power Backup: Enable Grid Sell Back: Enable Fast Zero Export: Disable Off-Grid Mode: Disable</p> <p><u>Charge:</u> AC Charge: Enable</p>
--

Off-Grid Mode: In this example, the AC-coupling configuration applies only when grid power is not present. When the grid is available, the AC-coupled inverter does not output power. The inverter operates in Off-Grid mode, and AC coupling provides supplemental power to the backup port and the smart loads while also assisting with battery charging. After the batteries reach full charge, AC-coupled power continues to support load operation. In this configuration, the non-backup port does not receive power because the grid input remains inactive, preventing AC coupling to supply the non-backup loads in off-grid mode.

<p style="text-align: center;">GridBOSS Settings:</p> <p><u>Battery Control (Common Settings):</u> Charge Control: SOC Discharge Control: SOC</p> <p><u>Grid Boss Smart Port #:</u> Smart Port Mode: AC Couple AC Couple Enable: Enable AC Couple Start & End SOC%: 30% & 100% AC Couple Start Time: 00:00 AC Couple End Time: 23:59</p>

<p style="text-align: center;">Inverter Settings:</p> <p><u>Application:</u> Power Backup: Enable Grid Sell Back: Disable Fast Zero Export: Enable Off-Grid Mode: Enable</p> <p><u>Charge:</u> AC Charge: Enable</p>

9. REMOTE SYSTEM MANAGEMENT

GridBOSS supports remote configuration and monitoring through the EG4® Monitor Center or the mobile app. To enable remote connectivity, install the included dongle into the communication port located on the upper-right side of the unit. Secure the dongle to the port using the four included screws.

After physically installing the dongle on the chassis, add the dongle's serial number and PIN to an EG4 user account to establish remote connectivity.

New EG4 users must create an account. Existing users can add the GridBOSS to an existing account, as described in Section 9.2.



9.1 CREATE NEW ACCOUNT

Using EG4® Monitor Center

1. Using a web browser, connect to “monitor.eg4electronics.com” and select “Register”.

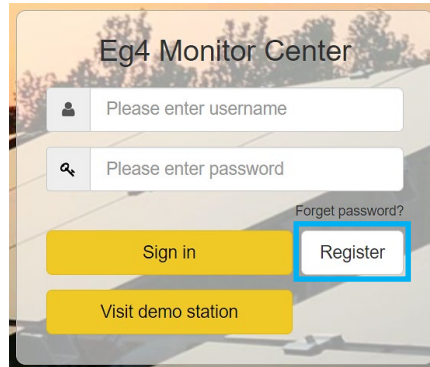

2. Complete the registration form as shown below. Obtain the customer code from the distributor. The dongle serial number (SN) and PIN appear on the sticker attached to the side of the dongle.

* Username	<input type="text" value="Username"/>
* Password	<input type="password" value="Password"/>
* Repeat password	<input type="password" value="Repeat password"/>
Nickname	<input type="text" value="Nickname"/>
* E-mail	<input type="text" value="E-mail"/>
Tel number	<input type="text" value="Tel number"/>
* Station name	<input type="text" value="Station name"/>
* Daylight saving time	<input type="radio"/> Yes <input checked="" type="radio"/> No
* Continent	<input type="text" value="North America"/>
* Region	<input type="text" value="North America"/>
* Country	<input type="text" value="United States of America"/>
* Timezone	<input type="text" value="—"/>
Address	<input type="text" value="Address"/>
* Customer code	<input type="text" value="Customer code"/>
* Dongle SN	<input type="text" value="Dongle SN"/>
* Dongle PIN	<input type="text" value="Dongle PIN"/>

3. After completing the registration, return to the EG4® Monitor Center web page and log in using the username and password created during the registration process.

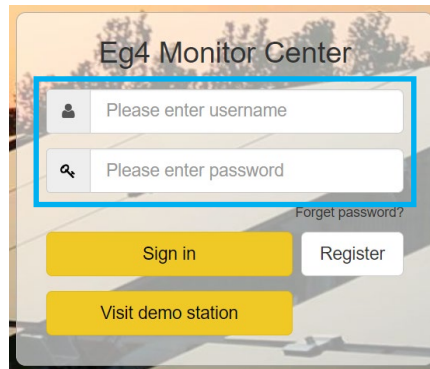

Using the Mobile App

1. Download the “EG4® Monitor” app for iOS or Android. After installation is complete, open the app.
2. Select “Register,” then complete the required information and select “Register.” Contact the distributor for the installer code.

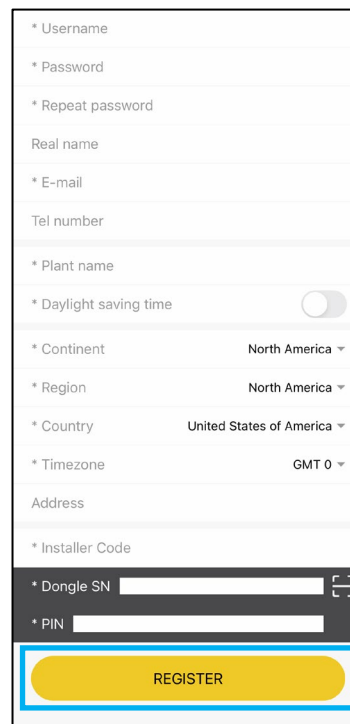
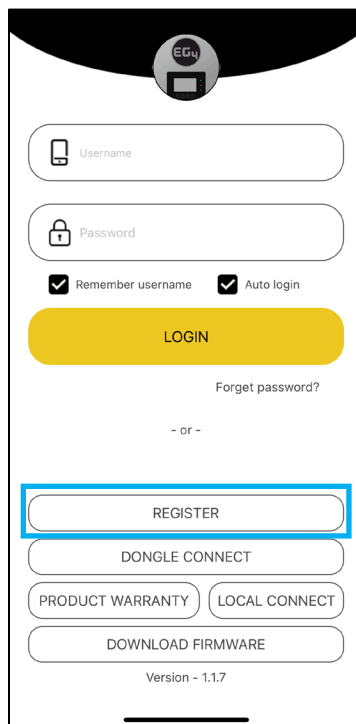

3. After completing the registration, return to the login page and log in using the username and password created during the registration process.

9.2 EXISTING ACCOUNTS

When an EG4® account already exists, newly added EG4 hardware that uses a dongle can be added to the account. This process can be completed through the EG4® Monitor Center or the mobile app.

Using EG4® Monitor Center

1. Using a web browser, open “monitor.eg4electronics.com” and log in with the existing username and password.

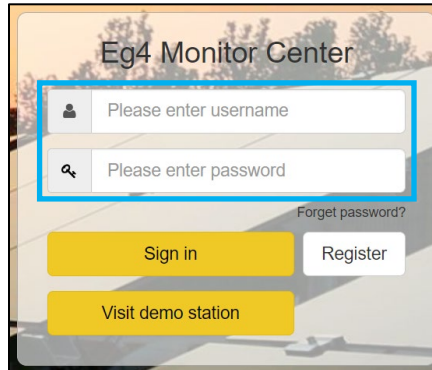

2. Select the “Configuration” tab, then select “Dongles.”
3. Select “Add Dongle”.
4. Enter the new dongle serial number and pin, select the station to assign the dongle, and then select “Add”.
5. GridBOSS should now be available in the Monitor Center.

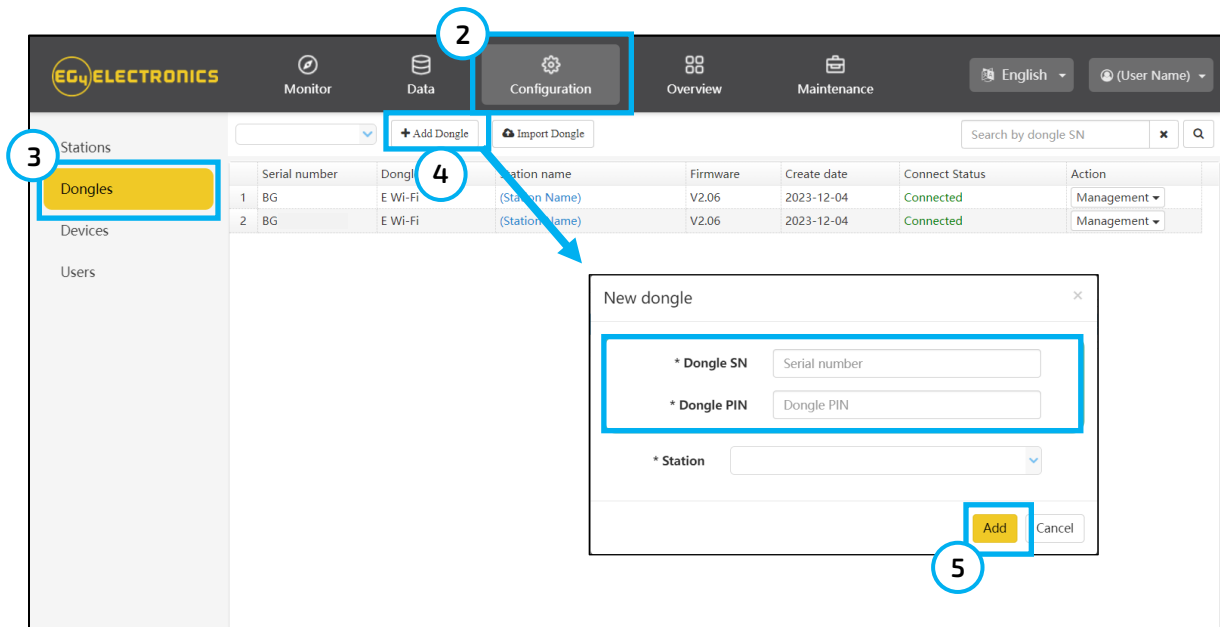

Using the Mobile App

1. Open the “EG4® Monitor” app and log in using an existing name and password.
2. Select the back arrow in the upper left corner of the screen.
3. Select “Add Dongle”.
4. Scan or enter the dongle information located on the dongle sticker, then select “Add Dongle”.

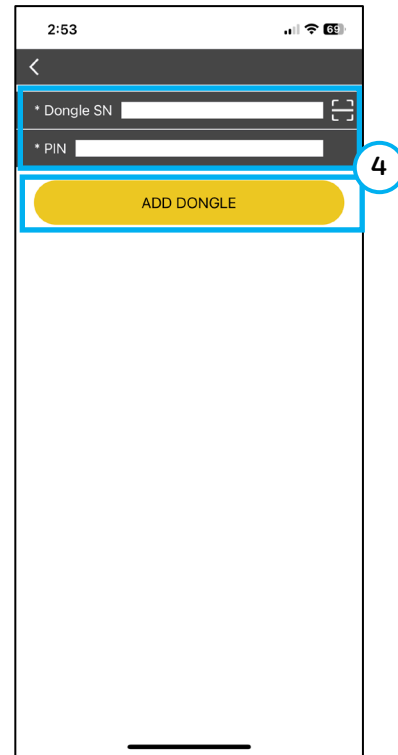
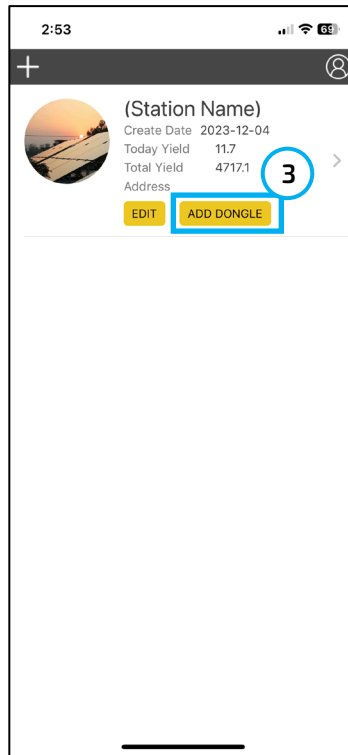
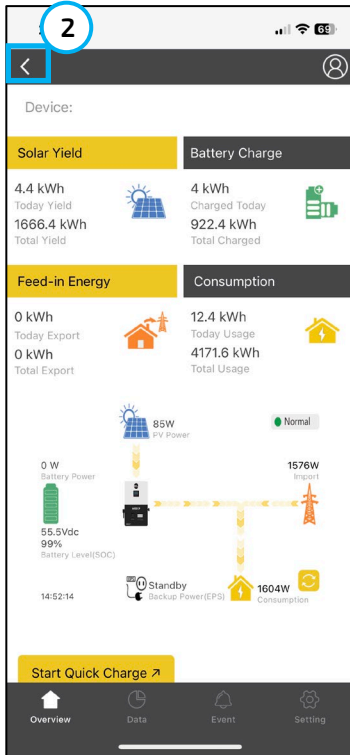

10. EG4 MONITOR CENTER

When viewing GridBOSS, new sections appear on the EG4® Monitor Center main page. All AC input and output information reflects the devices directly connected to the GridBOSS ports. All DC input and output information is obtained from the hybrid inverter.

- A. **Smart Ports:** Smart port information by port (numbered left to right)
- B. **Generator:** Generator information
- C. **Solar:** The total amount of incoming solar from all attached hybrid inverters
- D. **Inverter:** Attached hybrid inverter(s)
- E. **Grid:** Grid watts, AC voltage, and frequency attached to the GridBOSS grid port
- F. **Battery:** Total battery SOC, voltage, and watts
- G. **Load Ports:** Backup load and non-backup load output data

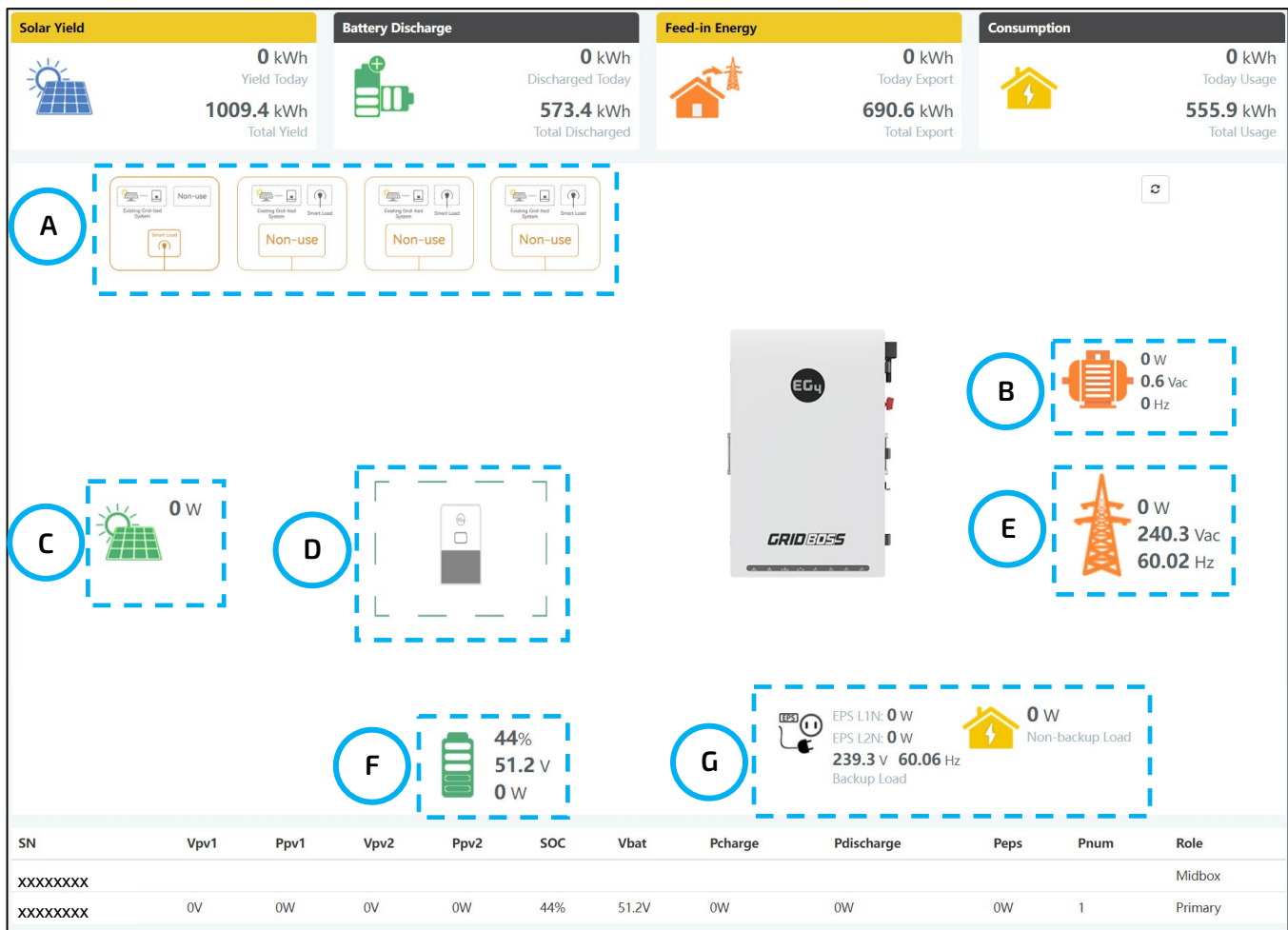

10.1 MAINTENANCE TAB

This section describes the settings for each area within GridBOSS. As a best practice, begin by selecting the “Read” button at the top of the maintenance page. This action refreshes the settings page and displays the values currently configured for each option.

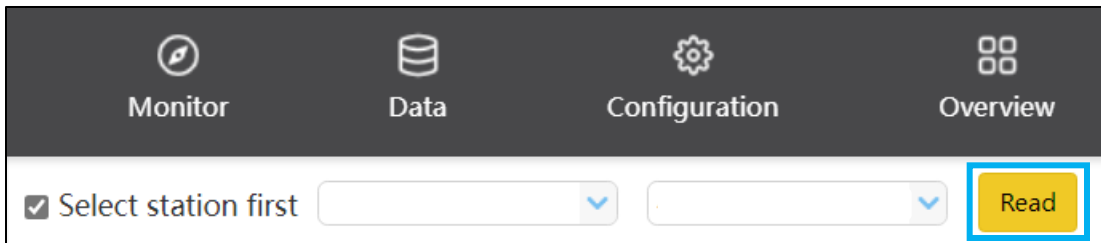

COMMON SETTING

Configure the time and charge/discharge control based on voltage or State of Charge (SOC). SOC is recommended when using closed-loop communication with LFP batteries. Use voltage when operating with lead-acid batteries or LFP batteries configured with the lead-acid setting.

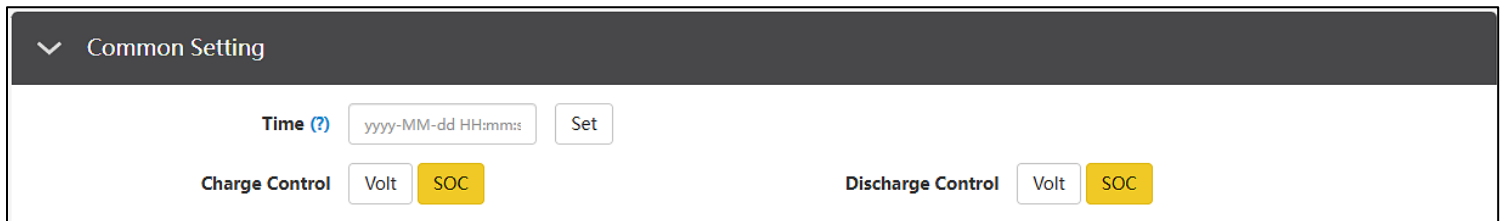

GRIDBOSS SMART PORTS 1-4

Four smart ports (1–4) can be configured as “Unused,” “Smart Load,” or “AC Couple.” The default setting is “Unused.” Before changing the port setting, press the “Read” button at the top of the page to display the currently configured settings. After reading the data, the Smart Port Mode changes from “<Empty>” to the current setting.

Select the desired working mode from the drop-down menu. Press the “Set” button to save the change. The smart port then displays the appropriate setting parameters for the selected port mode.

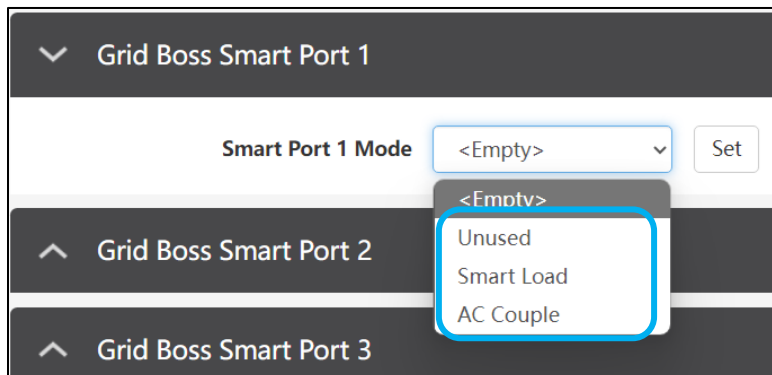

SMART LOADS

This section describes the various smart load settings. The smart port settings page contains three configuration areas. The first area manages load shedding and uses SOC/voltage to enable or disable the load port (outlined in blue). The objective is to turn off a smart load when the battery's State of Charge (SOC) reaches a low threshold. The second area manages power shedding, which adds PV power as a condition for enabling the load port (outlined in green). The objective is to activate a smart port when unused PV power is available to supply a load. The final area controls time-based operation, enabling or disabling a smart load based on defined time periods or combining time settings with SOC/voltage conditions.

Grid Boss Smart Port 1

Smart Port 1 Mode Smart Load Set

Smart load based on 1 <Empty> Set

Smart Load 1 Enable Enable Disable

Smart Load 1 Grid Always On (?) Enable Disable

Smart Load 1 Start SOC(%) (?) [0, 100] Set

Smart Load 1 End SOC(%) (?) [0, 100] Set

Smart Load 1 Start Volt(V) (?) [40, 59] Set

Smart Load 1 End Volt(V) (?) [40, 59] Set

Power Shedding Mode 1 Enable Disable

Smart Load 1 Power Shedding Start PV Power(kW) [0, 25.5] Set

Smart Load 1 Power Shedding Start SOC(%) (?) 0% [0, 100] Set

Smart Load 1 Power Shedding End SOC(%) (?) 0% [0, 100] Set

Smart Load 1 Power Shedding Start Volt(V) (?) 0V [40, 52] Set

Smart Load 1 Power Shedding End Volt(V) (?) 0V [48, 59] Set

	Start		End
T1	[0, 23] : [0, 59] Set	—	[0, 23] : [0, 59] Set
T2	[0, 23] : [0, 59] Set	—	[0, 23] : [0, 59] Set
T3	[0, 23] : [0, 59] Set	—	[0, 23] : [0, 59] Set

Smart Port Mode: Unused | Smart Load | AC Couple

Select “Smart Load” to configure the smart port with smart load settings.

Smart load based on: Empty | Time | SOC/Volt | Time + SOC/Volt

Select “Time” to configure the smart load based on a time period. Select “SOC/Volt” to configure the smart load based on battery SOC% or voltage level.

Smart Load Enable: Enable | Disable

Turns the smart load feature on or off. Always select disable until the port is fully configured and ready to be turned on.

Smart Load Grid Always On: Enable | Disable

Enable: The port relay will remain in the closed (on) position when there is grid input.

Disable: The port relay will operate based on time and/or SOC/Volt settings, regardless of the grid connection's state.

Load Shedding:

The smart load is configured using time periods and/or SOC/voltage. The port will be active if it is within the set time period and/or when the SOC or voltage exceeds the specified start value. The

port will be disabled if it is outside the specified time period and/or the end SOC/voltage is below the set value.

Smart Load Start & End SOC(%): [0, 100] and [0, 100]

The smart load port is enabled when above the starting SOC and disabled when below the SOC. Values are 0 – 100%.

Smart Load Start Volt: [40V – 59V]

The smart load port is enabled when above the defined voltage value.

Smart Load End Volt: [40V – 59V]

The smart load port is disabled when below the defined voltage value.

Smart Load Start Time: [00:00 – 23:59]

The smart load port is enabled at the defined start time. If one of the three time periods is met, the port relay will close (power on). Range is 00:00 – 23:59

Smart Load End Time: [00:00 – 23:59]

The smart load port is disabled according to the defined end time. Range is 00:00 – 23:59

Power Shedding:

PV power is included in the configuration when power-shedding mode is enabled. When “Grid Always On” is disabled and PV power exceeds the defined value, the port becomes enabled. If a time period and/or battery SOC/voltage condition is added to the start PV setting, all defined conditions must be met for the port to remain active. The port becomes disabled when the configured conditions fall outside the defined enable values. When “Grid Always On” is enabled and a grid connection is present, the port remains active regardless of PV input, time, or battery SOC/voltage conditions.

Smart Load Use Shedding Mode: Enable | Disable

Enable: Allows the port to use PV wattage to enable or disable power to the port.

Disable: Do not use PV wattage to enable or disable power to the port.

Smart Load Power Shedding Start PV Power(kW): 0 – 25.2kW

This is the low PV input threshold. When the PV input wattage goes below the set value, the port is disabled.

Smart Load Power Shedding Start & End SOC: [0, 100] and [0, 100]

The smart load port is enabled above the starting SOC and disabled when below the SOC. Values are 0 – 100%.

Smart Load Power Shedding Start Volt (V): [40V – 59V]

The smart load port is enabled when above the defined voltage value.

Smart Load Power Shedding End Volt (V): [40V – 59V]

The smart load port is disabled when below the defined voltage value.

Smart Load Start Time: [00:00 – 23:59]

The smart load port is enabled at the defined start time. If one of the three time periods is met, the port relay will close (power on). Range is 00:00 – 23:59

Smart Load End Time: [00:00 – 23:59]

The smart load port is disabled according to the defined end time. Range is 00:00 – 23:59

AC COUPLE

This section describes the various AC coupling settings. During AC coupling configuration, the enablement and start/stop parameters are set within the GridBOSS settings area of the EG4[®] Monitor Center. Certain inverter settings also interact with the functionality of the GridBOSS AC-coupled port.

When the inverter operates in on-grid mode, the GridBOSS disregards the battery’s SOC and voltage. The AC-coupled relay closes (powers on) when the hybrid inverter’s “Export to Grid” setting is enabled and the defined time period conditions are met. The GridBOSS also opens (powers off)

the AC-coupled port relay when the hybrid inverter’s “Export to Grid” function is disabled, preventing power from being exported to the grid.

When the inverter operates in off-grid mode, the GridBOSS controls the AC-coupled relay based on the battery SOC, voltage, and/or defined time period conditions. The relay also opens (powers off) if the inverters receive excessive power from the AC-coupled inverter.

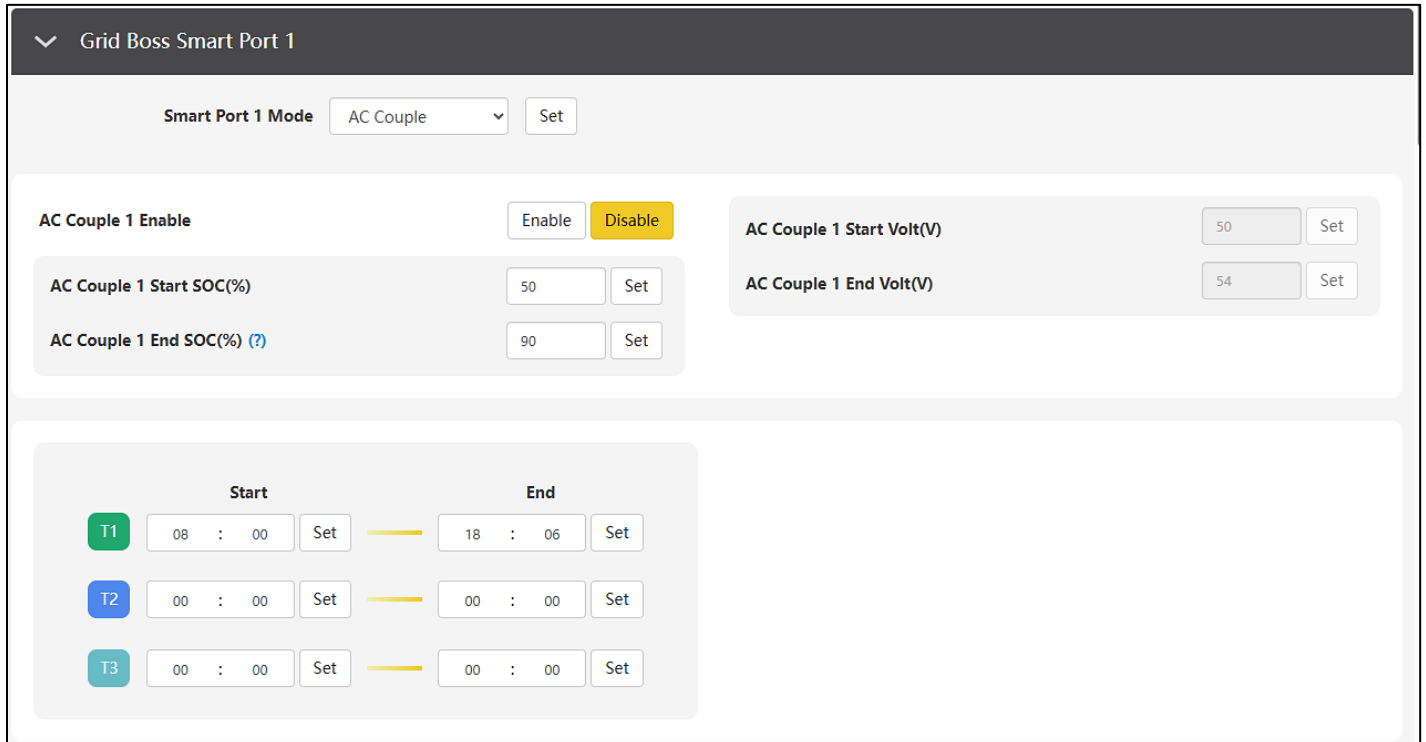

Smart Port Mode: Unused | Smart Load | AC Couple

Select AC Couple to enable the smart port to be configured with AC Couple settings.

AC Couple Enable: Enable | Disable

Turns the AC couple feature on or off. Always select “Disable” until the port is fully configured and ready to be turned on.

AC Couple Start & End SOC(%): [0 – 100] and [0 – 100]

The SOC values that enable and disable the AC coupled port

AC Couple Start Volt: [40V – 59V]

The AC couple port is enabled when below the configured voltage value.

AC Couple End Volt: [40V – 59V]

The AC couple port is disabled when above the configured voltage value.

AC Couple Start Time: [00:00 – 23:59]

The AC couple port is enabled at the defined start time. If one of the three time periods is met the port relay will close (power on). Range is 00:00 – 23:59

AC Couple End Time: [00:00 – 23:59]

The AC couple port is disabled at the defined end time. Range is 00:00 – 23:59

GENERATOR

All generator settings are configured on the GridBOSS through the EG4® Monitor Center or the EG4 app. The inverter generator settings are not used, except for the “GEN Boost” setting. When “GEN Boost” is disabled at the inverter, the inverter operates according to the generator settings configured on the GridBOSS. When “GEN Boost” is enabled at the inverter, the inverter operates based on the GridBOSS generator power setting minus 400W.

Generator SOC/Vbat Enable	<input type="button" value="Enable"/> <input type="button" value="Disable"/>	Generator Remote Turn On/Off	<input type="button" value="Enable"/> <input type="button" value="Disable"/>
Batt Charge Current Limit(Adc) (?)	<input type="text" value="[0, 250]"/> <input type="button" value="Set"/>	Gen Rated Power(kW) (?)	<input type="text" value="[0, 25.5]"/> <input type="button" value="Set"/>
Charge Start Volt(V)	<input type="text" value="[40, 57]"/> <input type="button" value="Set"/>	Charge Start SOC(%)	<input type="text" value="[0, 100]"/> <input type="button" value="Set"/>
Charge End Volt(V)	<input type="text" value="[42, 59]"/> <input type="button" value="Set"/>	Charge End SOC(%)	<input type="text" value="[0, 100]"/> <input type="button" value="Set"/>
Generator Warm Up Time(s)	<input type="text" value="[30, 600]"/> <input type="button" value="Set"/>	Generator Remote Auto Turn off time(m)	<input type="text" value="[5, 20]"/> <input type="button" value="Set"/>

Generator SOC/Vbat Enable: Enable | Disable

Enable or disable generator charging based on the State of Charge (SOC) or battery voltage. If disabled, the generator will not be controlled using SOC or battery voltage, and remote turn on/off must be used.

Generator Remote Turn On/Off: Enable | Disable

Manual control of dry contact 1. Set to enable to start the generator or set to disable to stop the generator.

Batt Charge Current Limit (Adc): [0 – 250]

Set the battery charging limit based on DC amperage.

Gen Rated Power (kW): [0 – 25.5]

Set the maximum generator input power.

Charge Start Volt: [40 – 59V]

The generator starts using dry contact 1 when the battery voltage is below the charge start voltage setting. Set according to the battery requirements.

Charge End Volt: [40 – 59V]

Stops the generator using dry contact 1 when the battery voltage exceeds the charge end voltage setting. Set this according to the battery requirements.

Charge Start SOC: [0 – 90%]

The generator starts using dry contact 1 when the battery SOC is below the charge start SOC setting. Set this according to the battery requirements.

Charge End SOC: [20 – 100%]

Stops the generator using dry contact 1 when battery SOC is above the charge end SOC setting. Set this according to the battery requirements.

Generator Warm Up Time(s): [30 – 600]

Sets the “Generator Warm Up Time” in seconds. The generator relay closes only after the warm-up period completes. The GridBOSS restarts the warm-up period if abnormal generator voltage is detected during the warm-up process.

Generator Remote Auto Turn off time(m): [5 – 20]

Sets the “Generator Remote Auto Turn Off Time” in minutes. GridBOSS automatically powers off the generator based on the configured Auto Turn-off Time. This setting can also support a generator exercise function.

11. FIRMWARE UPDATES

Before commissioning the system, confirm that the GridBOSS and inverter firmware are fully up to date. During firmware upgrades, the GridBOSS and inverters use system firmware. The 12kPV and 18kPV inverters also use LCD firmware. System firmware can be updated through the EG4® mobile app or the Monitor Center, as described below.

11.1 SYSTEM - EG4 MOBILE APP



NOTE

When updating firmware through the EG4 app, maintain sufficient battery charge on the device and do not close the app during the update process. Before performing the following steps, verify that the Wi-Fi dongle is securely connected and properly configured.

1. Open the mobile device's wireless settings. Locate and select the dongle's serial number as the Wi-Fi network. The dongle's network ID will be the same as the dongle's serial number.
2. Open the EG4 app and select "LOCAL CONNECT." The app should now be connected to the inverter or GridBOSS (whichever was selected in step 1).
3. With the app still running, return to the mobile device's Wi-Fi settings. Connect the home
4. Wi-Fi network for internet access.
5. Switch back to the EG4 app on the mobile device. Select the correct device type from the drop-down menu. Then select the "DOWNLOAD" button. To view the firmware change log, select the "Changelog" button.
6. Once the check mark appears beside each firmware package, the download is complete. If the check marks do not appear, confirm that the Wi-Fi is connected to the home network and not the dongle serial number.
7. With the app still running, go back to the mobile device's Wi-Fi settings. Connect the mobile device back to the Wi-Fi dongle's network.
8. Switch back to the EG4 app and select the "CONNECT DEVICE AND UPDATE" button. Next select the "Update Firmware" button. The firmware update process should begin. Do not close the app or change wireless settings while the update is taking place.
9. Once the update is complete, the app will display "Update firmware successfully".

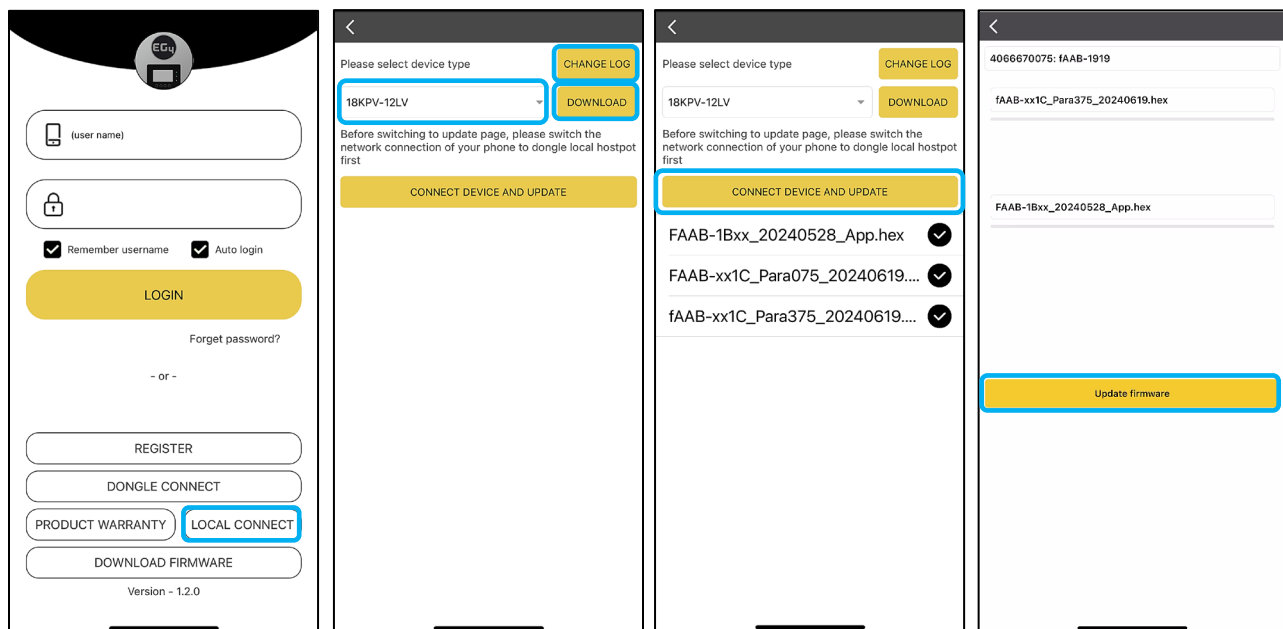
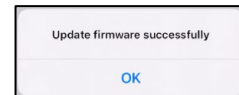

11.2 SYSTEM - EG4 MONITOR CENTER

1. Log in to the EG4® Monitor website. Select the “Maintenance” tab.
2. Select “Remote Update” on the left side of the screen.
3. Locate the unit needing the update by serial number. Select the blue question mark box next to the current firmware version.
4. Select “Check more” to view the release notes for the latest release. Close the release notes.
5. Select the “Upgrade Policy” checkbox, then select the “Standard Update” button to initiate the firmware update process. The Monitor Center begins updating both firmware files for the inverter.

The screenshot illustrates the EG4 Monitor Center interface during a firmware update process. The top navigation bar includes 'Monitor', 'Data', 'Configuration', 'Overview', and 'Maintenance' tabs. The 'Maintenance' tab is active, showing a 'Remote Update' section on the left with a 'Remote Update' button. A table lists units with columns for 'Serial number', 'Dongle', 'Firmware version', 'Connect Status', and 'Action'. A 'Check Updates' dialog box is open, showing details for a unit with serial number 1 and firmware version FAAB-1D1D, with a 'Check more ->' link. A 'Firmware Change log' window is open, showing a list of updates and a detailed log for EG4_FAAB-1B1C. The 'Check Updates' dialog also has a 'Read Firmware version upgrade policy' checkbox and 'Standard Update' and 'Cancel' buttons.

11.3 INVERTER LCD – USB DRIVE

Follow the steps below to update the inverter LCD firmware. A 2GB – 16GB USB flash drive is required. This update requires the inverter to shut down and restart.

Download the LCD firmware file using the QR code listed below. The firmware update is listed under Inverters > 18kPV > Firmware.



EG4 LCD Firmware

LCD Update Steps:

1. Plug the USB flash drive into a Windows PC.
2. Format the flash drive using the following settings:
 - File system: FAT32
 - Allocation unit size: 4096 Bytes
 - Select “Quick Format”
3. Press “Start” to format the USB flash drive. **ALL** existing data on the flash drive will be **ERASED!**
4. Create a folder on the flash drive named **DWIN_SET**
5. Extract the downloaded zip file containing the LCD firmware to the DWIN_SET folder created on the flash drive.
6. Open the DWIN_SET folder on the flash drive and verify there are seven total files as follows:
 - .bin (4 files)
 - .icl (2 files)
 - .CFG (1 file)

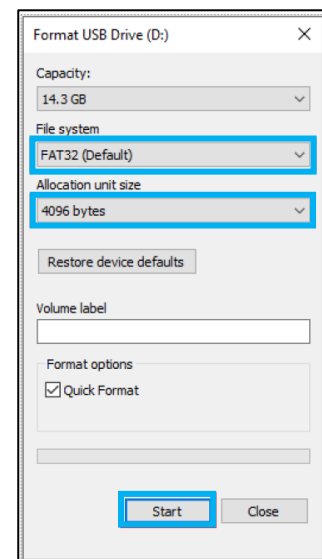

In file explorer, use the “Details” view and make sure “File name extension” is checked.

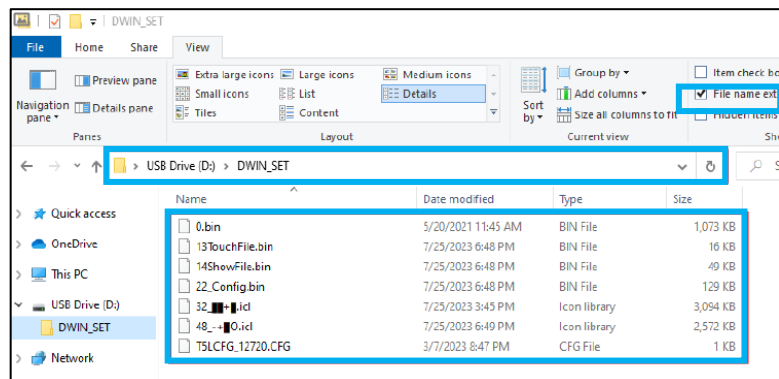

7. Safely remove the USB flash drive from the computer.
8. Power off the inverter.
9. Insert the USB flash drive into the USB port on the inverter's communications board, as shown in the image.
10. After the USB flash drive has been connected, power on the inverter. **DO NOT** power off the inverter during the update process.

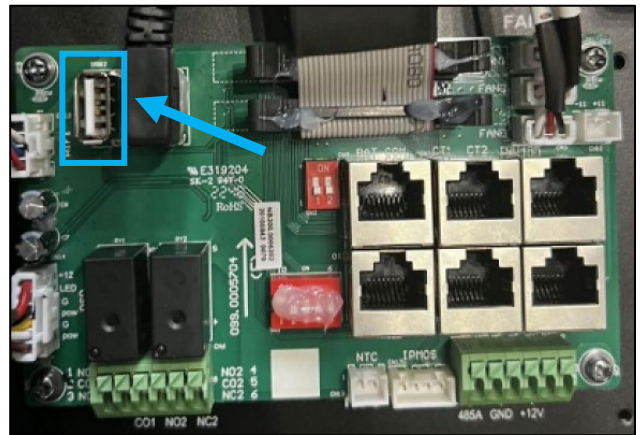

11. The inverter will display a loading screen for 3 – 5 minutes.
12. After the LCD resets, navigate to:
13. Settings → Device info. → LCD version
14. to confirm that the LCD was correctly updated.

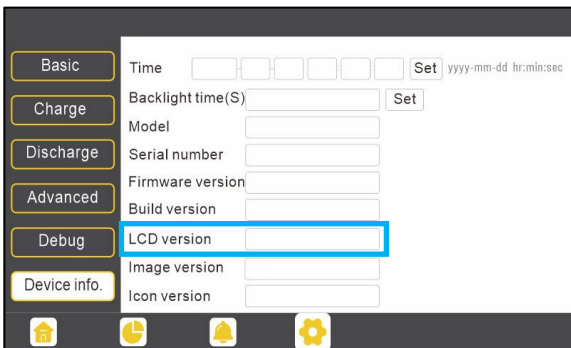
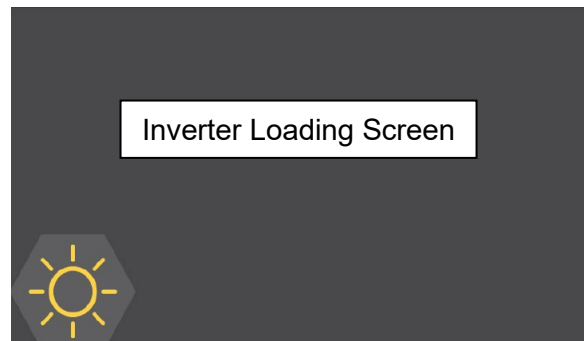

12. TROUBLESHOOTING

12.1 FRONT PANEL LEDS

The front panel LEDs indicate the operating status of each port or group of ports. A port operating normally displays a solid green LED. If a fault occurs, the affected port displays a flashing green LED. During a firmware update, all port LEDs flash green.

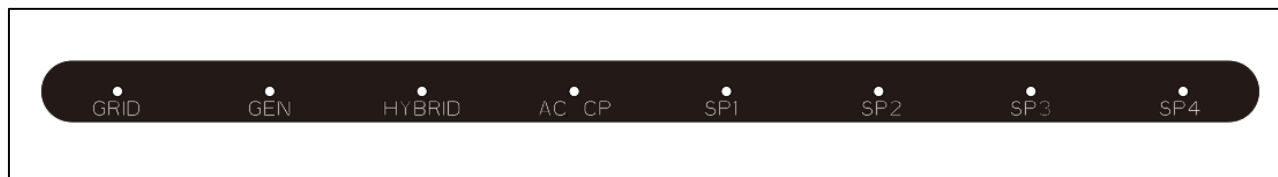

LED FAULT INDICATORS:

PORT	LED	STATUS
GRID	Blink every 100 ms	Load overcurrent
GEN	Blink every 100 ms	Generator overcurrent
HYBRID	Blink every 100 ms	EPS load overcurrent The parallel RSD alarm is triggered The inverter is running old firmware The inverter stops outputting
	Blink every 500 ms	CAN communication cable is disconnected
AC CP	Blink every 100 ms	AC-coupled port cannot be closed
SP1 – SP4	Blink every 100 ms	Smart port overcurrent Smart port 4 trigger NEC PCS protection

12.2 ERROR CODES

CODE	INFO	DESCRIPTION	RECOMMENDATION
E004	Inverter Firmware Mismatch	The inverter is running an older firmware that is not compatible with the GridBOSS.	Update the inverter FW to a version supported by the GridBOSS.
E005	NEC Protection	The current is more than 80% of the maximum current value supported by the busbar.	Verify that the total system load is less than 80% of the maximum busbar limit setting. Reduce system load to under 80%.
E006	Grid OCP	Grid port has overcurrent protection	Verify the grid port load does not exceed 220A for more than 1 minute.
E007	NBC Load OCP	Non-backup Load port has overcurrent protection	Verify the non-backup port load does not exceed 220A for more than 1 minute.
E008	GEN OCP	The generator port has overcurrent protection	Verify the generator port does not exceed 137.5A for more than 1 minute.
E009	BC Load OCP	Backup Load port has overcurrent protection	Verify the backup load port does not exceed 220A for more than 1 minute.
E010	Smart Port 1 OCP	Smart Port 1 has overcurrent protection	Verify the load on SP1 does not exceed 137.5A for more than 1 minute.
E011	Smart Port 2 OCP	Smart Port 2 has overcurrent protection	Verify the load on SP2 does not exceed 88A for more than 1 minute.

E012	Smart Port 3 OCP	Smart Port 3 has overcurrent protection	Verify the load on SP3 does not exceed 66A for more than 1 minute.
E013	Smart Port 4 OCP	Smart Port 4 has overcurrent protection	Verify the load on SP4 does not exceed 66A for more than 1 minute.

12.3 WARNING CODES

CODE	INFO	DESCRIPTION	RECOMMENDATION
W000	Parallel comm fault	Parallel CAN communication fault	Check the parallel CAN cable between the GridBOSS and the master inverter.
W003	Load Shedding Overload	The smart load power exceeds the configured load shedding power limit	The port will resume operation, and the error will reset once the smart load power is below the configured load shedding power limit.
W006	RSD Active	RSD is active in the system	Turn off the RSD switch to restart the system.
W015	A trip by Gen Freq or Voltage abnormal	<ol style="list-style-type: none"> The generator frequency is not within 45~60Hz. The generator voltage is not within the range of (Grid Volt Limit 3 Low -10V) to (Grid Volt Limit 3 High+10V). 	Generator voltage and frequency must be within the supported range.
W016	No AC connection	No AC connection or power outage.	Verify the grid is up and that all grid breakers/switches are in the closed position.
W017	A trip by Vac abnormal	<ol style="list-style-type: none"> The grid voltage exceeds the protection voltage range of Grid Volt Limits 1, 2, and 3, and the duration exceeds the specified Grid Volt Limit Time for Grid Volt Limits 1, 2, and 3. The moving average value of the grid voltage exceeds the maximum allowable limit defined by the Grid Volt Mov Avg High safety regulation. 	Verify that the grid voltage is within the supported range.
W018	A trip by Fac abnormal	The grid frequency exceeds the Grid Freq Limits 1, 2, and 3, and the duration exceeds the specified Grid Freq Limit Time 1, 2, and 3.	Verify that the grid frequency is within the supported range.

12.4 INTERNAL FUSE REPLACEMENT

GridBOSS contains two internal fuses that protect the unit from overcurrent conditions. One fuse protects Line 1, and the other protects Line 2. If fuse replacement becomes necessary, follow the steps listed below. Before starting the replacement procedure, locate the two spare fuses supplied with the GridBOSS.



Before working on the unit, verify that all breakers are in the off position and that there is no voltage or current at each breaker and lug connection point.

1. The front inner black cable box cover must be removed to obtain access to the fuse area. Open the front door by releasing the three clasps on the right side of the unit. Next, remove the four screws as identified in the image below and then carefully remove the inner black cable box cover by lifting it out of the chassis.

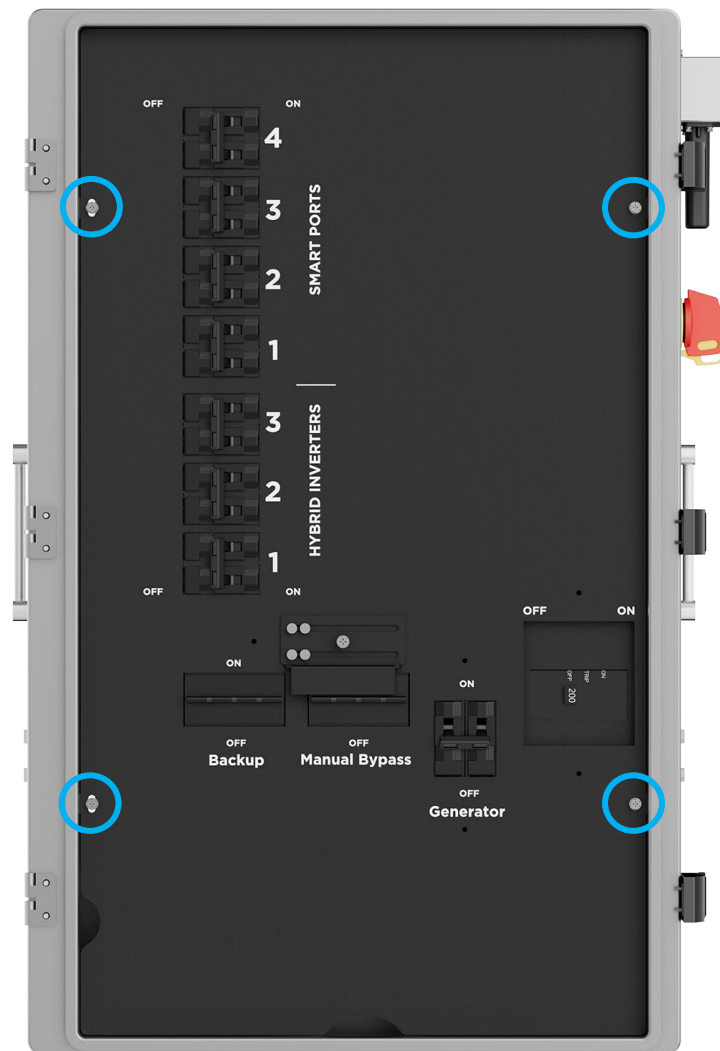

2. Unscrew the two M4x10 screws to remove the breaker bracket, then pull the bracket away from the chassis.

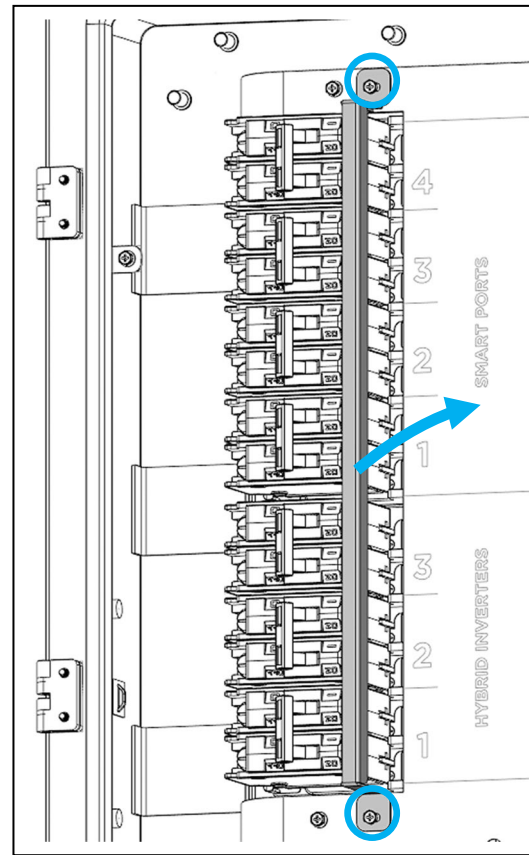

3. Remove the internal orange cover by first removing the two nuts using a 7mm socket and the four screws using a Phillips screwdriver. Then, lift the cover out of the unit.

4. Locate the two internal fuses outlined in blue in the image below.

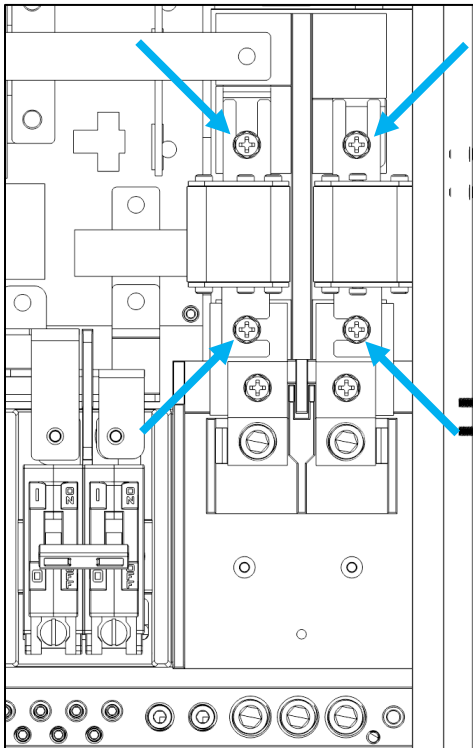
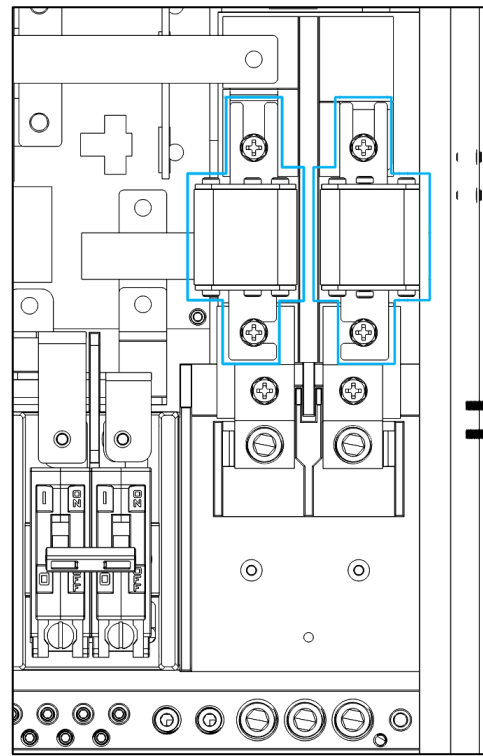

5. Remove the M6 screws (2 per fuse) as indicated by the blue arrows. Then, remove each fuse.

- Set the new fuse in place. Verify that the direction of the fuse matches the image below. Position the smaller notch, open to the side, toward the grid input, and direct the longer notch, open to the end, toward the inside of the chassis.

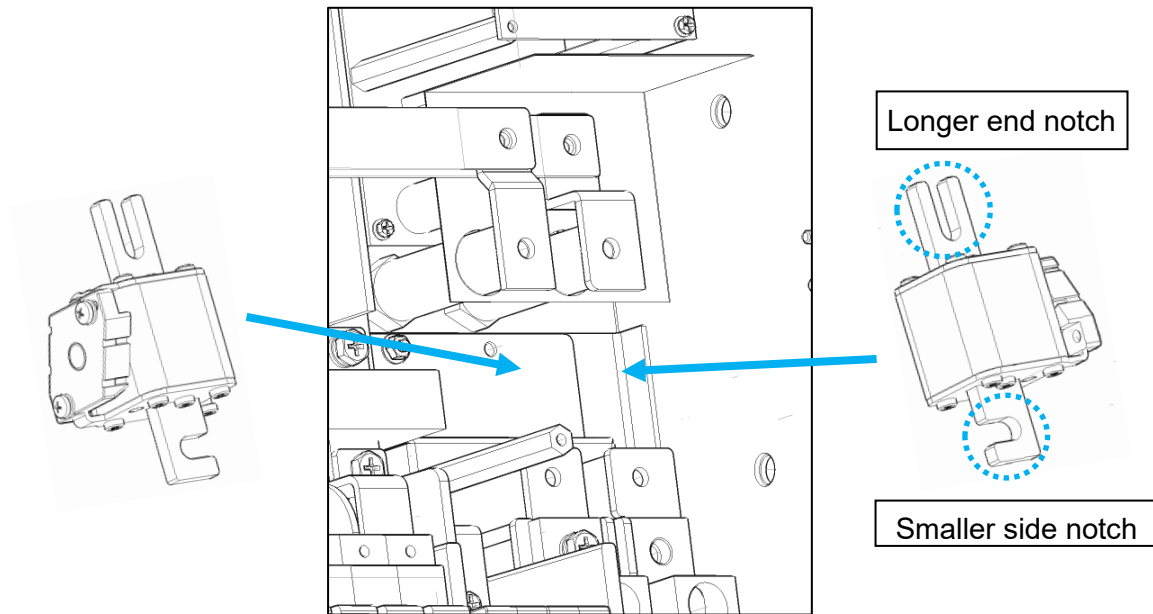

- Reinstall the four M6 screws and tighten to 80 in-lbs. (9.0Nm).



NOTE

Position the plastic insulator between the fuses before securing them when replacing the fuse in Model 3 units. Model 4 units use a plastic insulator that remains in place during replacement.

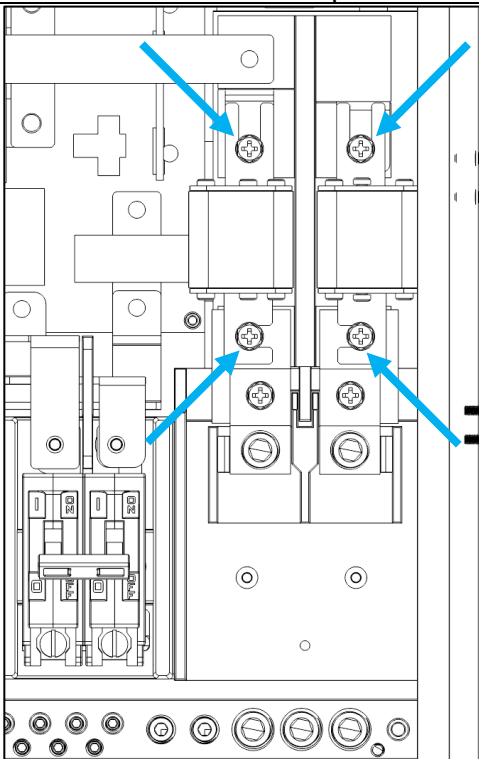

- Reinstall the orange inner cover plate removed in step 3.
- Reinstall the breaker bar removed in step 2.
- Reinstall the inner black cable box cover removed in step 1
- The system is now ready for use.

13. CHANGELOG

V2.0.6

- Added additional safety information to sections 3 & 4
- Added informational note to spec sheet regarding installations above 2000 m

V2.0.5

- Updated slave inverter DIP switches from up position (ON) to down position (OFF)

V2.0.4

- Added grounding screw to packing list
- Updated screw count & type in packing list
- Updated operating altitude specs

V2.0.3

- Added model 4 to footnote on cover page
- Added CSA C22.2#107.1 to specifications
- Added model 4 hardware main breaker installation steps and fuse replacement steps
- Updated images in the installation section to reflect model 3 main lug aread

V2.0.2

- Updated breaker footnotes to include SKU numbers for model 3 hardware, indicating whether breakers are included in the box or not

V2.0.1

- Modified FlexBOSS18 breaker size to 70A
- Added QR code to Hybrid Inverter RSD Wiring Guide

V2.0

- Initial document release

EG4

ELECTRONICS

support@eg4electronics.com
(903) 609-1988
www.eg4electronics.com